

A8PF (Fixed Plugin) Eksenel Pistonlu Pompa

High Pressure Hydraulic Bent Axis Piston Pumps, High Pressure, 450/500 BAR Working Pressure. High Rotational Speed, High Efficiency, Slim Design, Cast Iron Pump Body, Re-Designed in 2025.

Designation;

28cc, 32cc, 41cc, 50cc, 56cc,
63cc, 80cc, 90cc, 108cc, 125cc

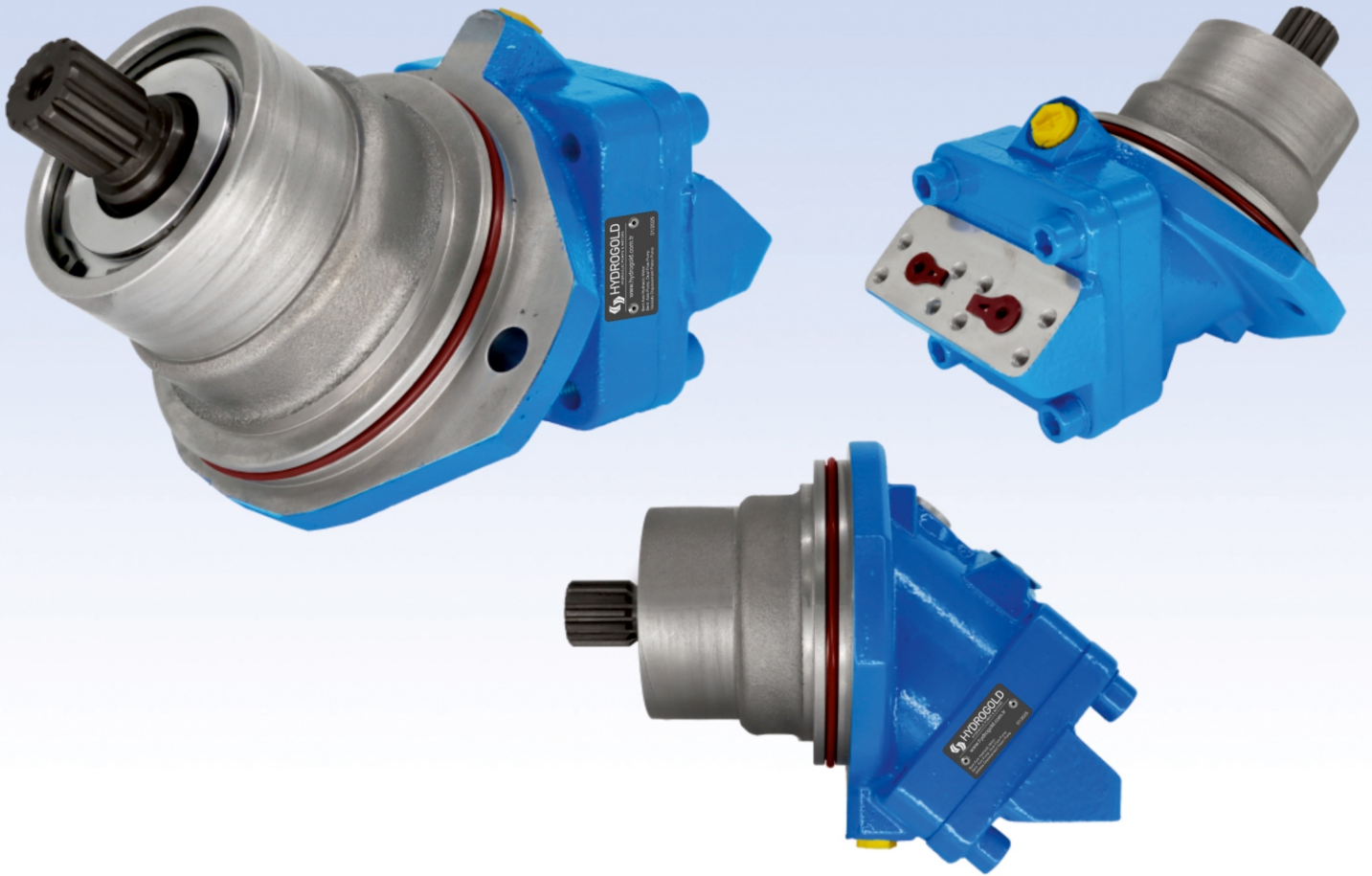

www.hydrogold.com.tr

Characteristics of the A8PF (Fixed Plugin) Flange Bent Axis Pumps

Pump MODEL	DISPL. (cc)	CONTINUOUS MAX. SPEED (rpm)	INTERMITTED MAX. SPEED (rpm)	MAX. FLOW ABSORBED (l/mn)	TORQUE BAR (m.N/bar)	TORQUE AT 350 BAR (m.N)	THEORETCL MAX. POWER AT 400 BAR (HP / kW)	MAX. ALLOW PRESSURE CONTN./PEAK (bar)	WEIGHT (kg)
28 cc	28.0	6300	6900	158	0.40	139	140.0 / 104.4	400 / 450	11.4
32 cc	32.0	6300	6900	202	0.50	178	180.5 / 134.4	400 / 450	11.5
41 cc	41.0	5600	6200	230	0.65	228	205.2 / 153.1	400 / 450	11.6
50 cc	50,3	5000	5500	252	0.80	280	224.1 / 167.5	400 / 450	18.1
56 cc	56,0	5000	5500	280	0.90	320	244.5 / 187.1	400 / 450	18.1
63 cc	63.0	5000	5500	315	1.00	351	281.6 / 209.1	400 / 450	18.2
80 cc	80,4	4500	5000	362	1.27	447	323.6 / 241.5	400 / 450	26.1
90 cc	90,1	4500	5000	405	1.43	500	361.5 / 269.9	400 / 450	26.2
108 cc	108	4000	4400	435	1.70	598	328.8 / 245.6	400 / 450	33.2
125 cc	125	3400	4400	428	2.00	698	382.6 / 284.6	400 / 450	33.8

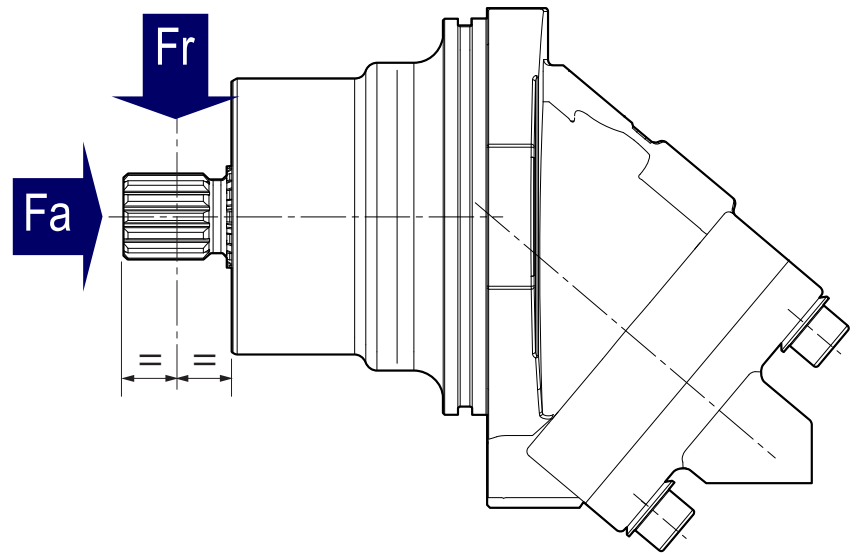

Pump model	28 cc	32 cc	41. 45	50 cc	56, 63cc	80,90,108	125 cc
Fr (lbf)	1350	1462.5	1462.5	1686	2023	2812	3262
Fr (N/bar)	6000	6500	6500	7500	9000	12500	14500
Fa (lbf)	0.42	0.46	0.62	0.62	0.77	1.24	1.33
Fa (N/bar)	(27)	(30)	(40)	(40)	(50)	(80)	(86)

Ordering Code; A8PF (Fixed Plugin) Bent Axis Pumps

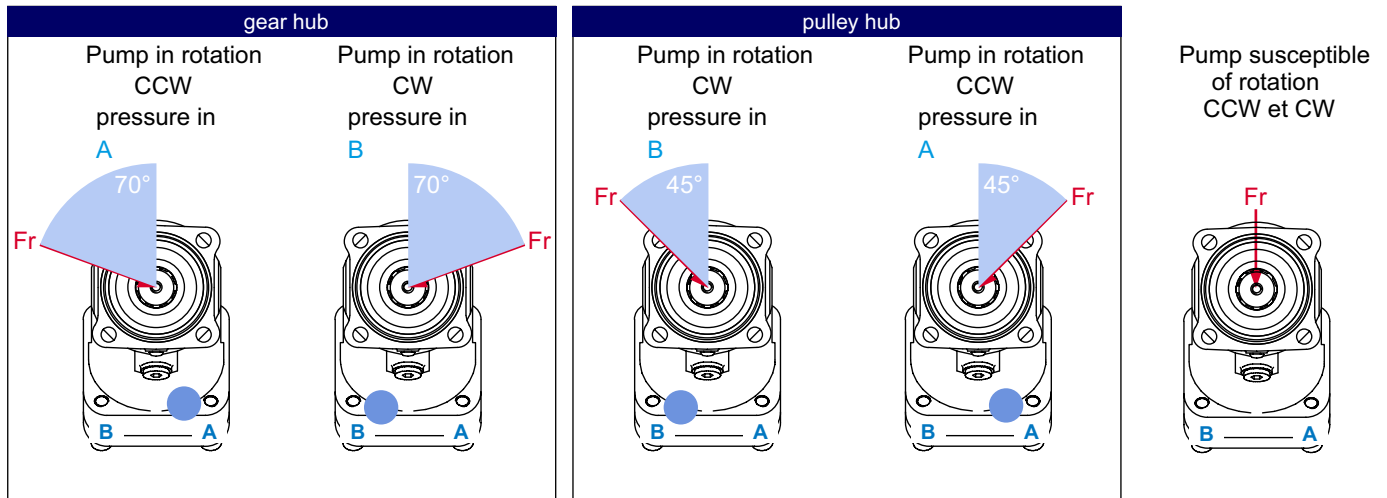
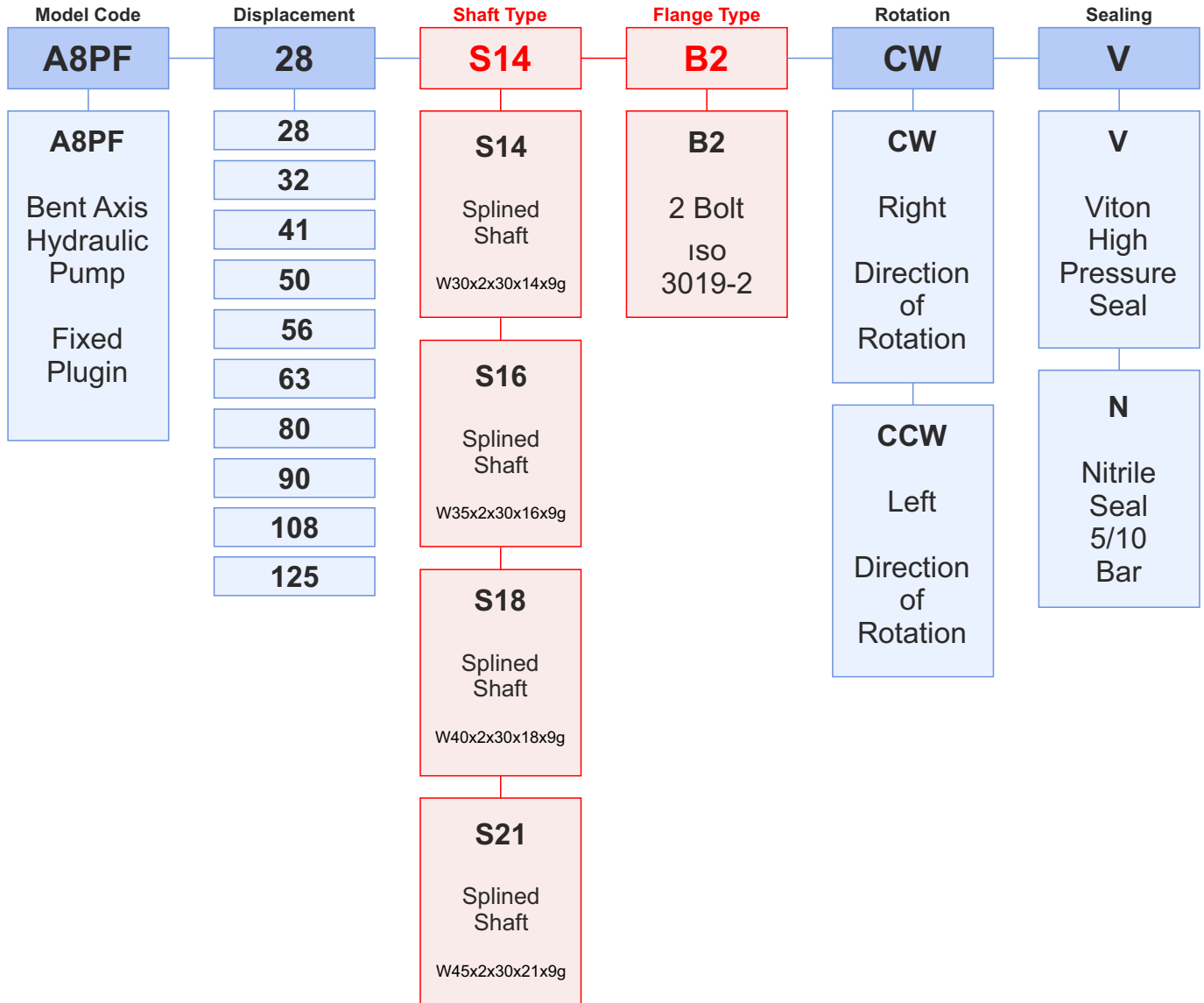

A8PF - 28 cc (Fixed Plugin) - 2 Bolt

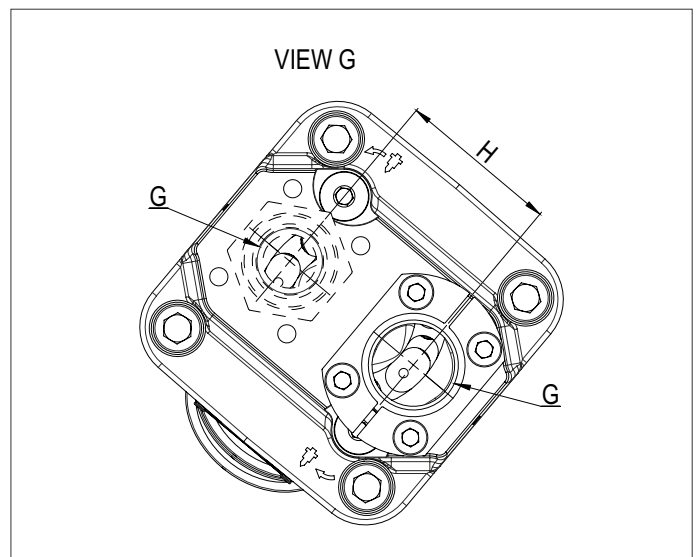
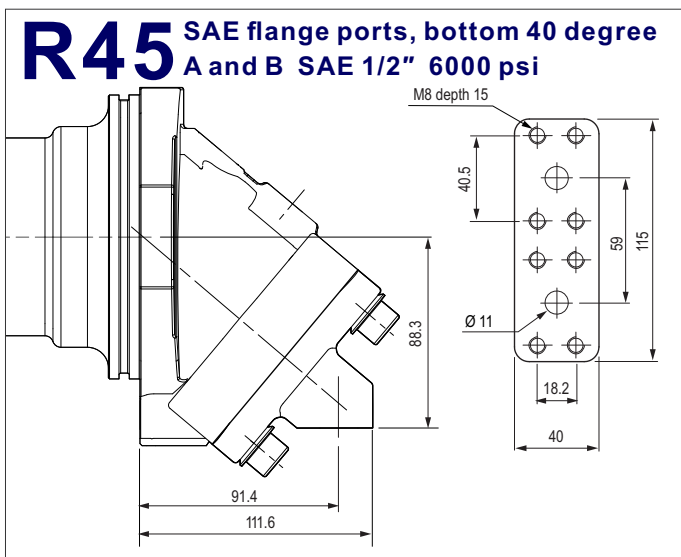
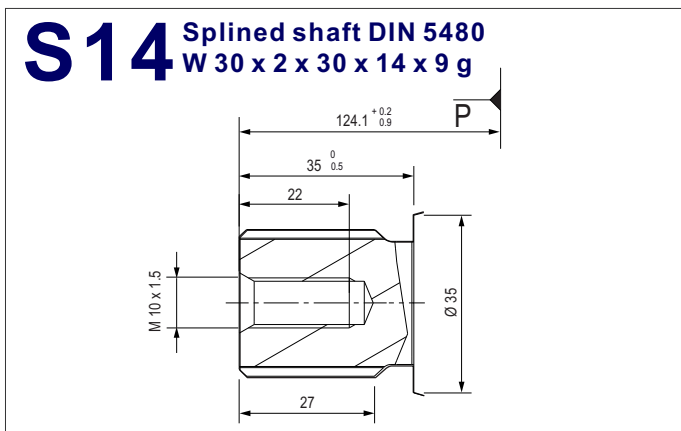
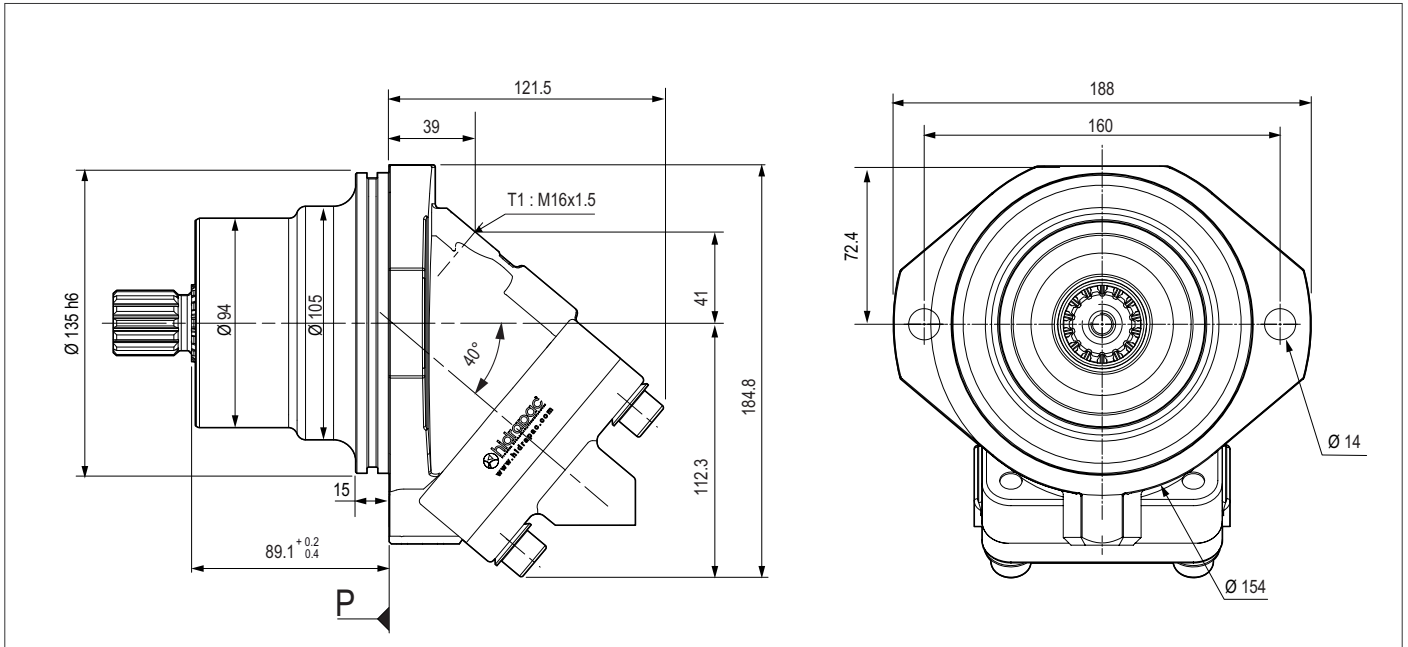

A8PF - 32 cc (Fixed Plugin) - 2 Bolt

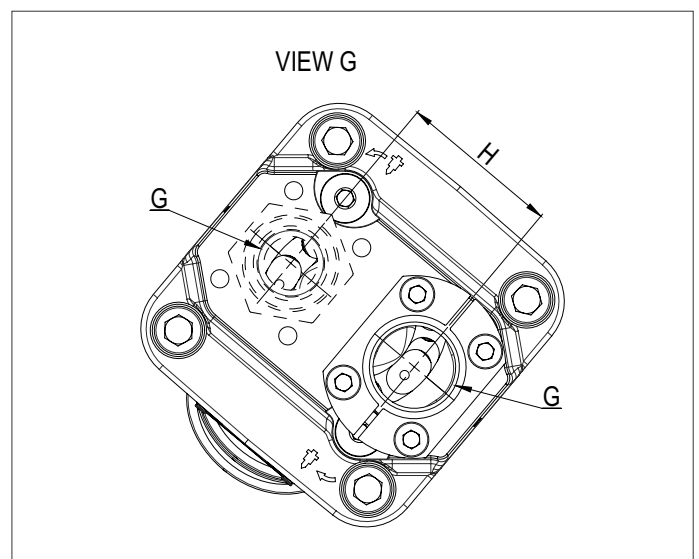
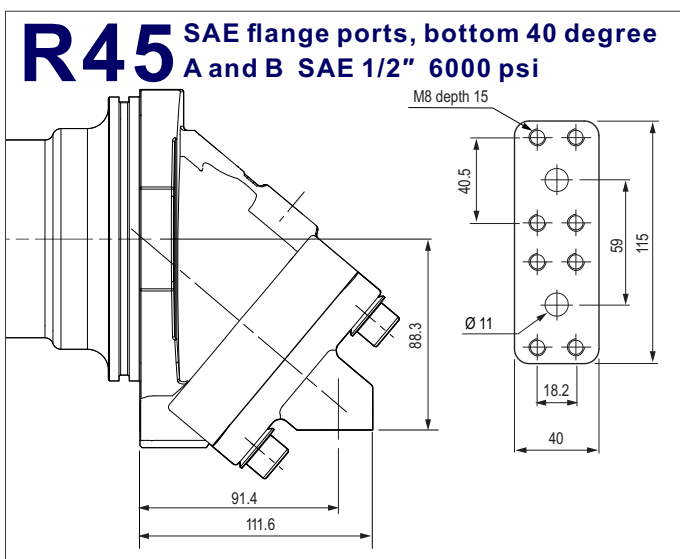
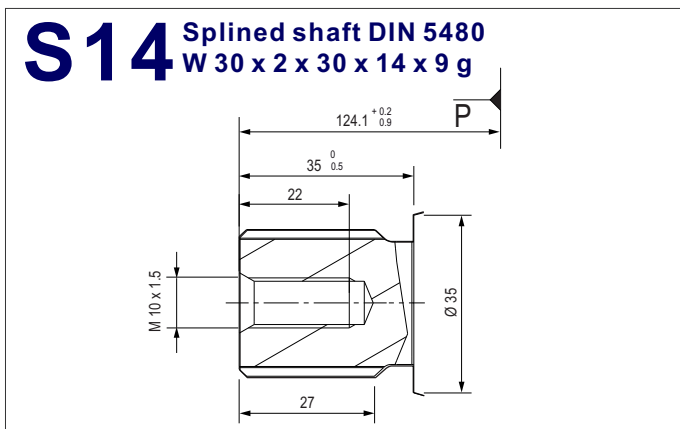
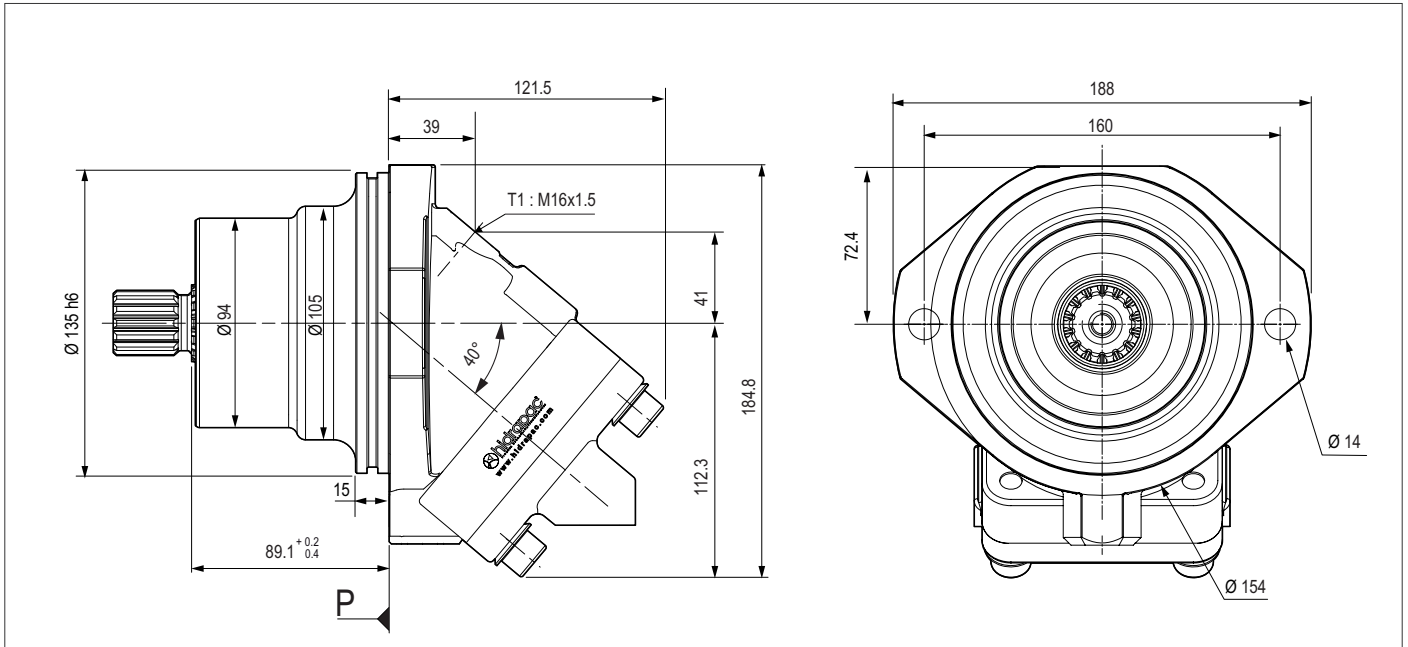

A8PF - 41 cc (Fixed Plugin) - 2 Bolt

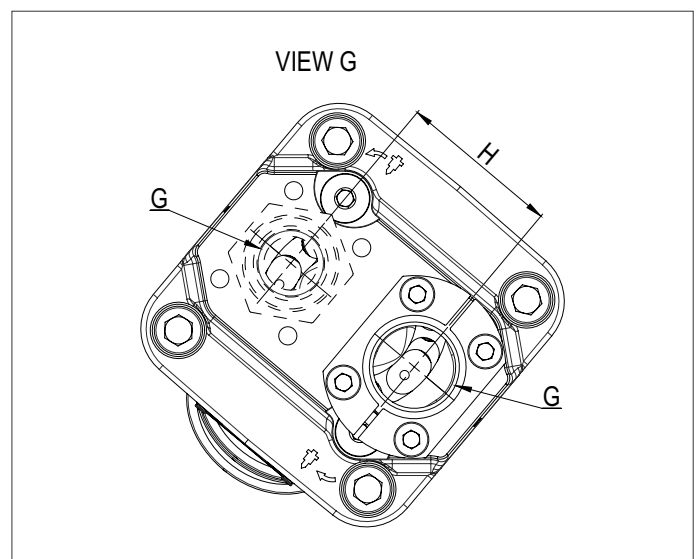
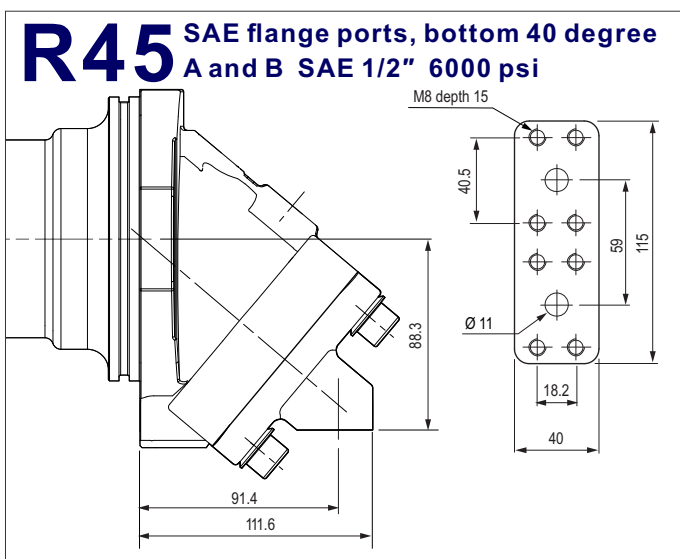
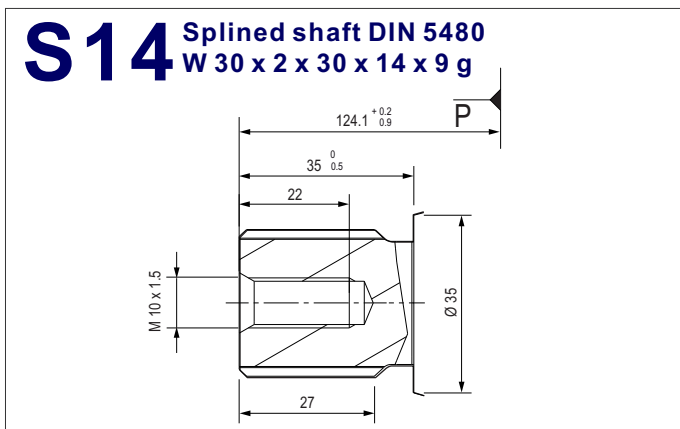
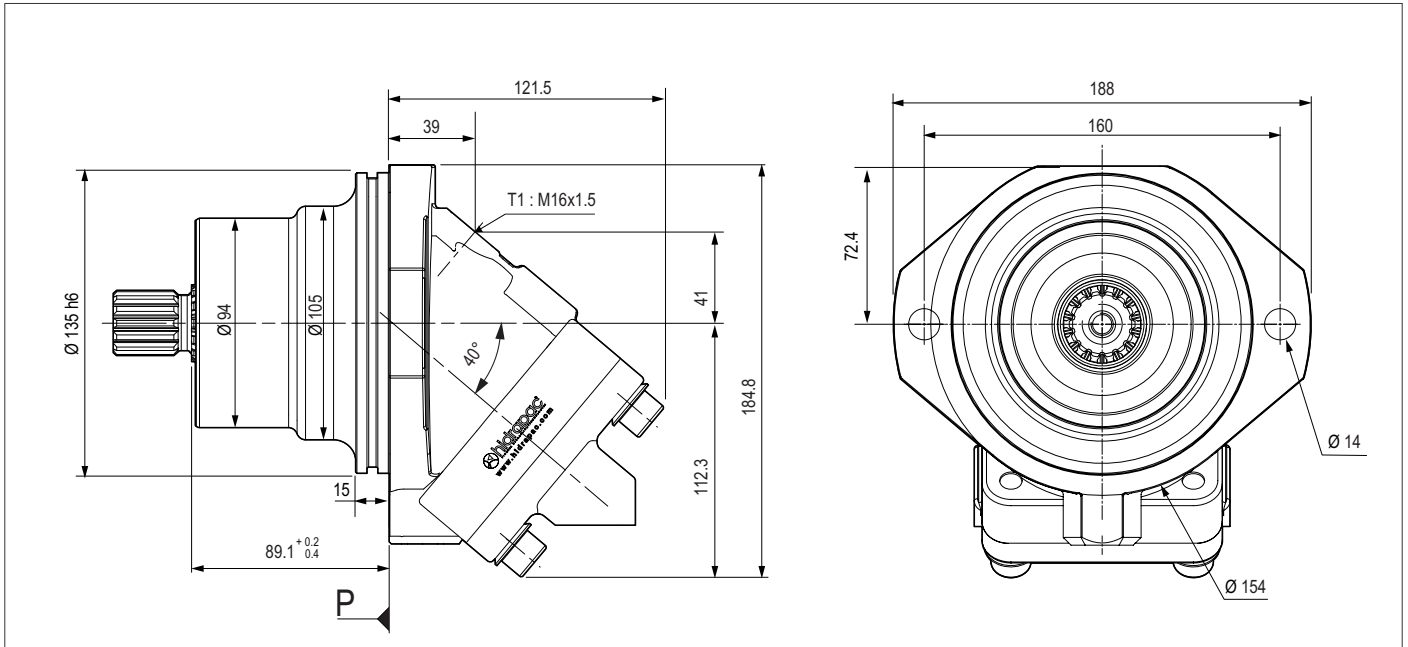

A8PF - 50 cc (Fixed Plugin) - 2 Bolt

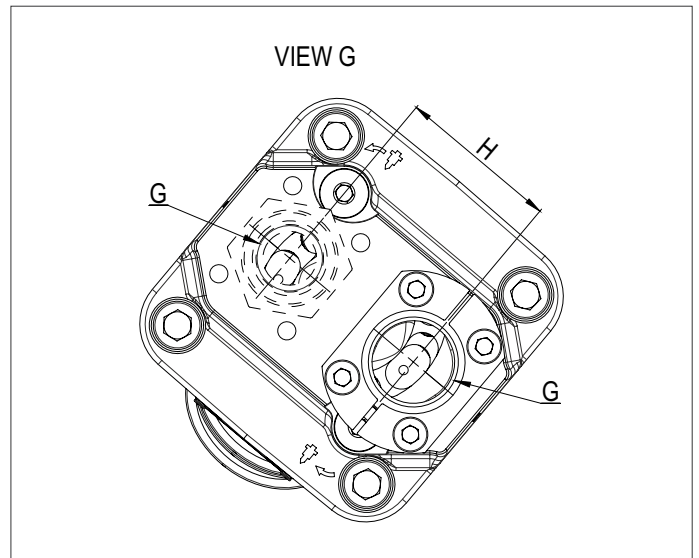
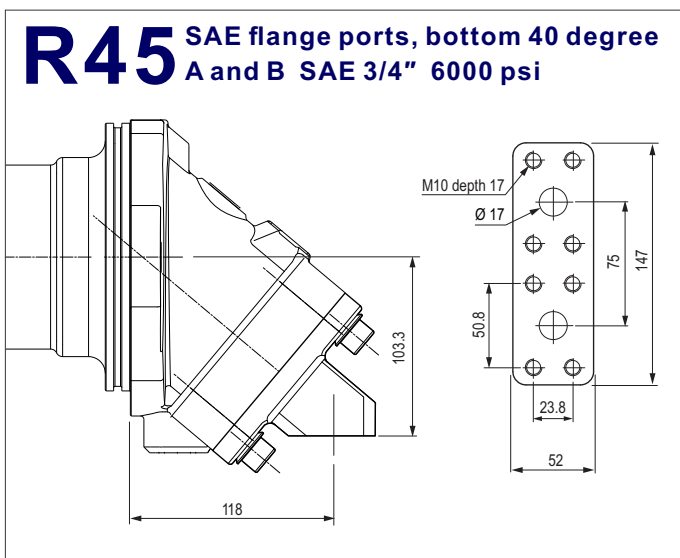
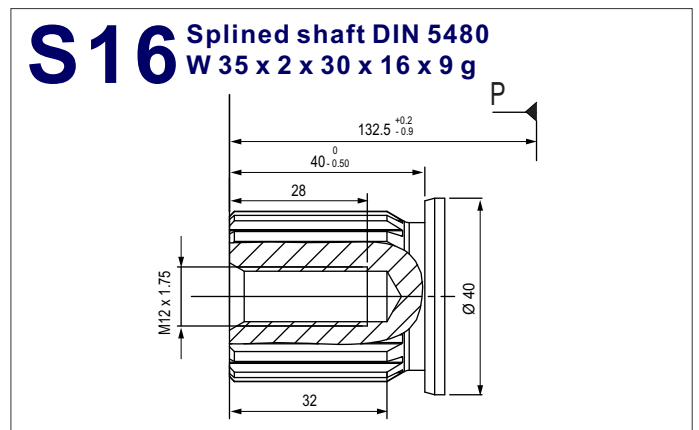
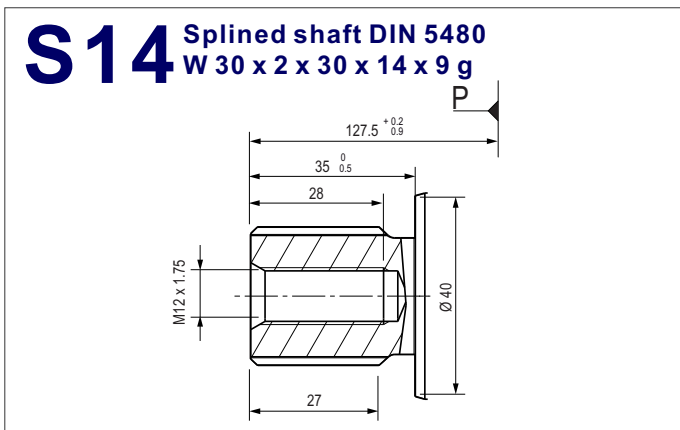
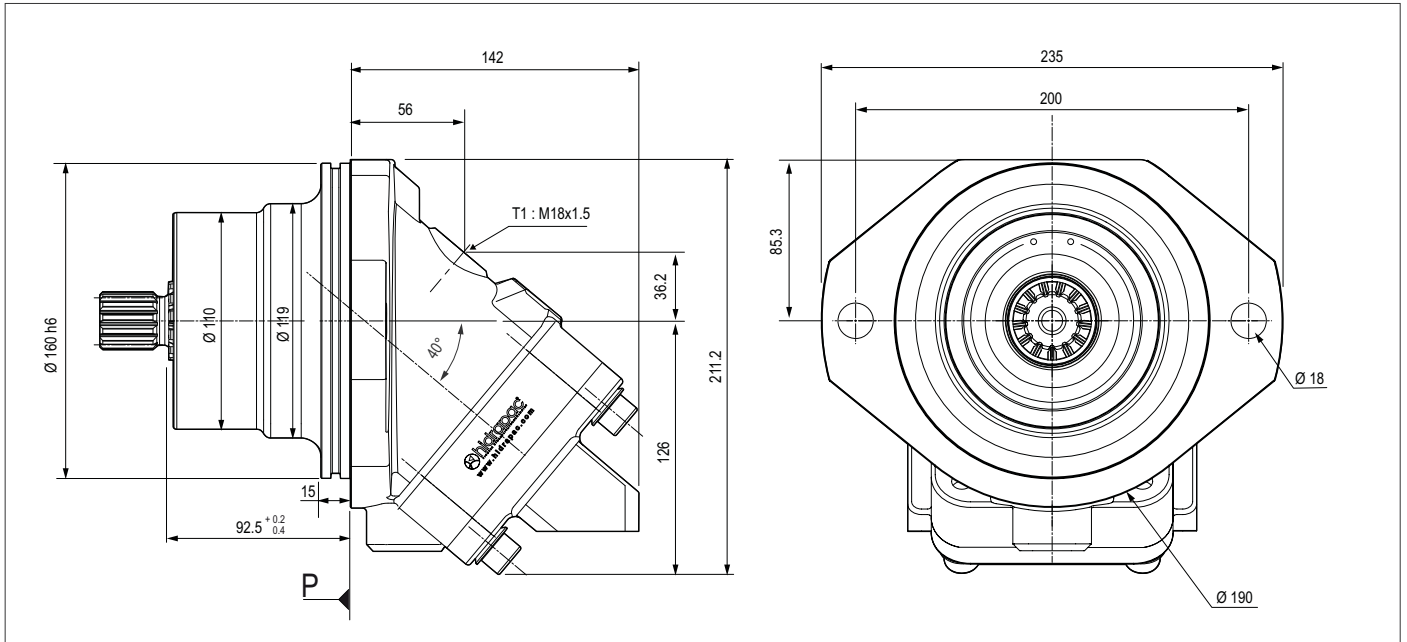

A8PF - 63 cc (Fixed Plugin) - 2 Bolt

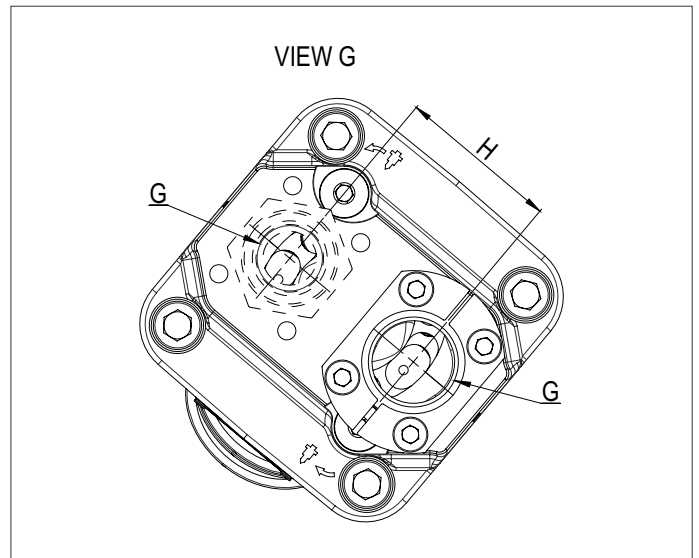
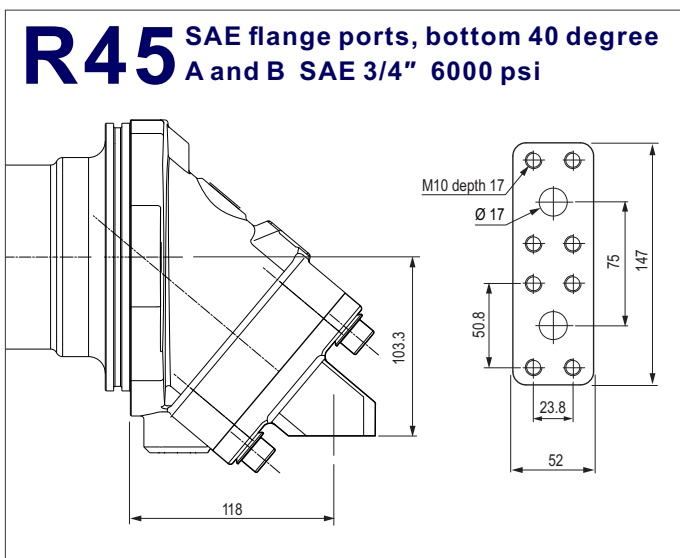
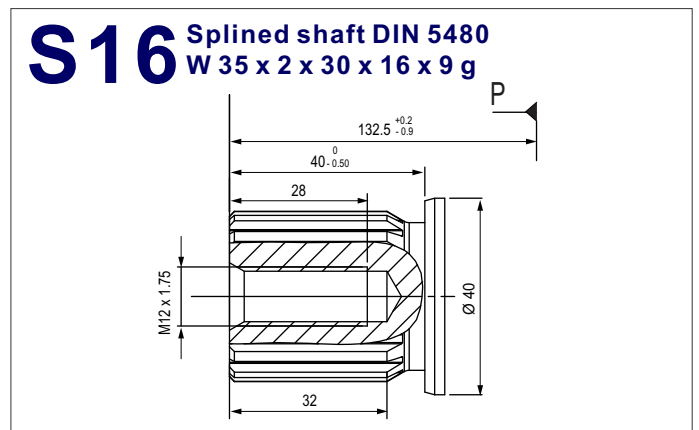
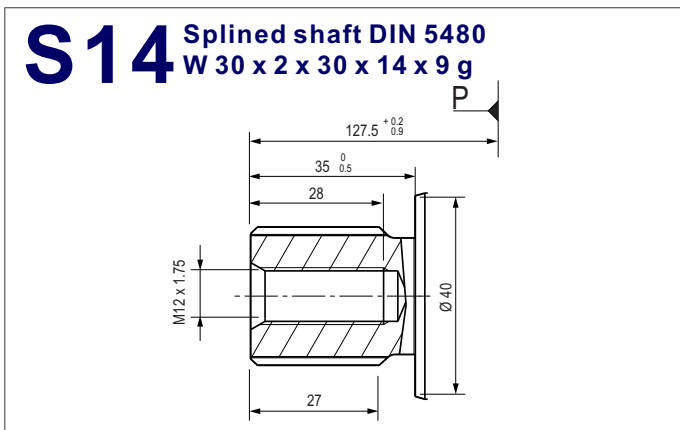
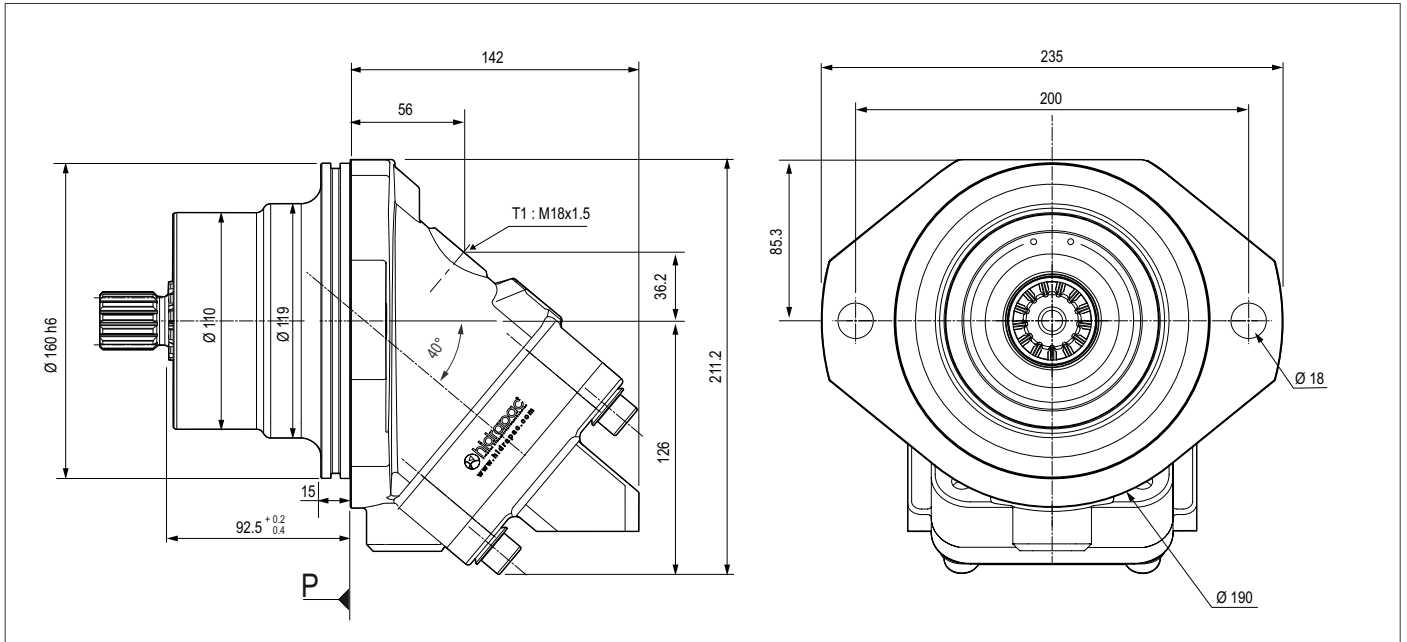

A8PF - 80 cc (Fixed Plugin) - 2 Bolt

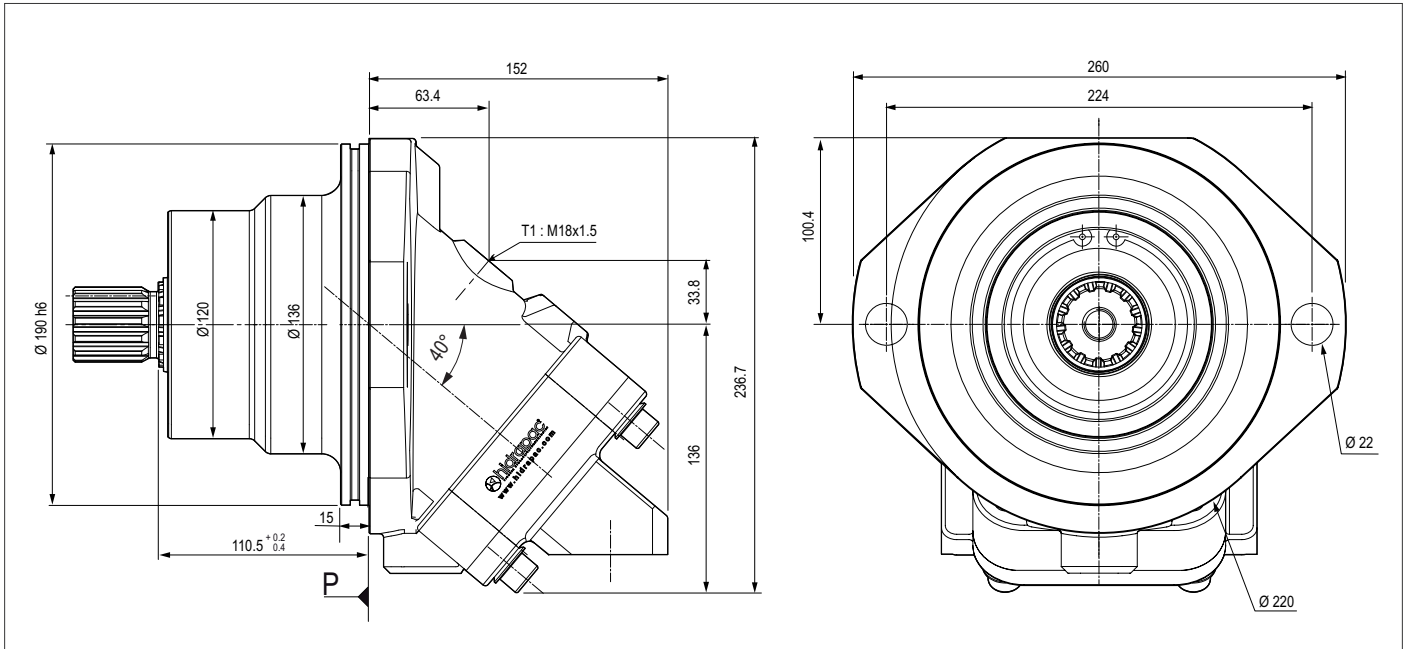

S18 Splined shaft DIN 5480 W 40 x 2 x 30 x 18 x 9 g

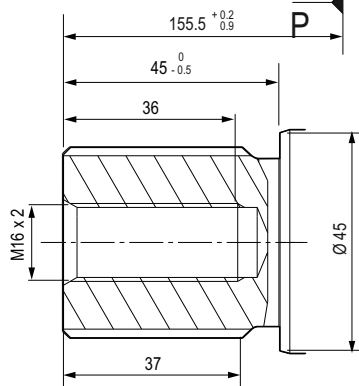

S16 Splined shaft DIN 5480 W 35 x 2 x 30 x 16 x 9 g

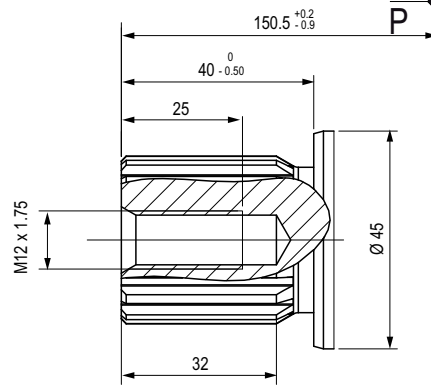

R45 SAE flange ports, bottom 40 degree A and B SAE 1" 6000 psi

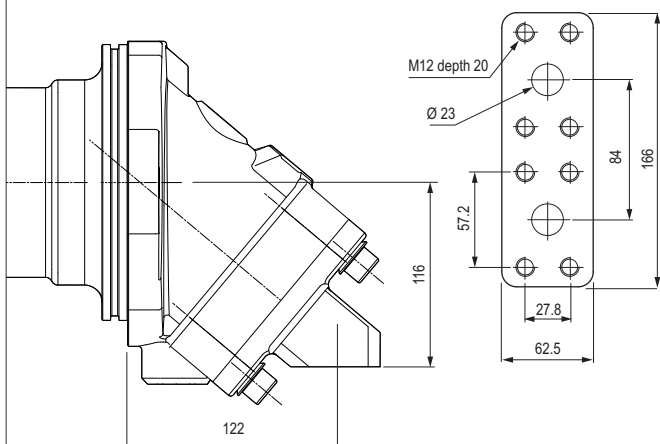

VIEW G

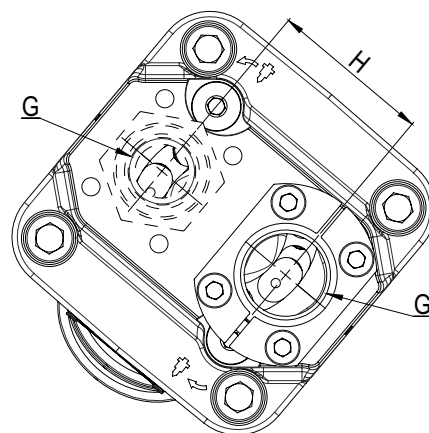

A8PF - 90 cc (Fixed Plugin) - 2 Bolt

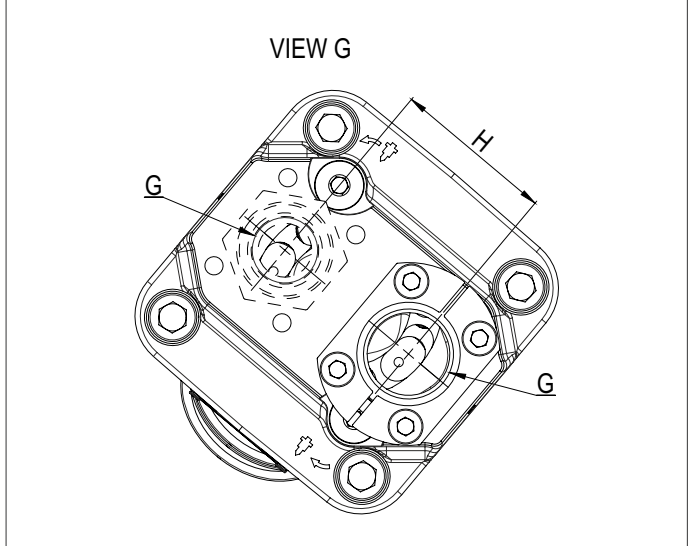
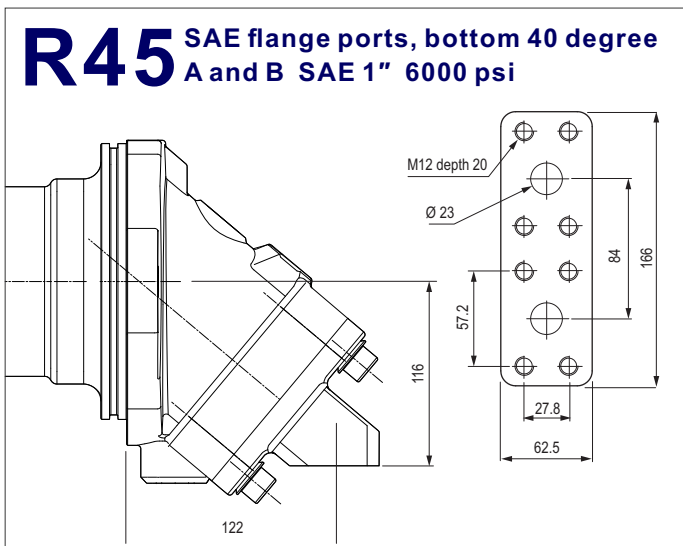
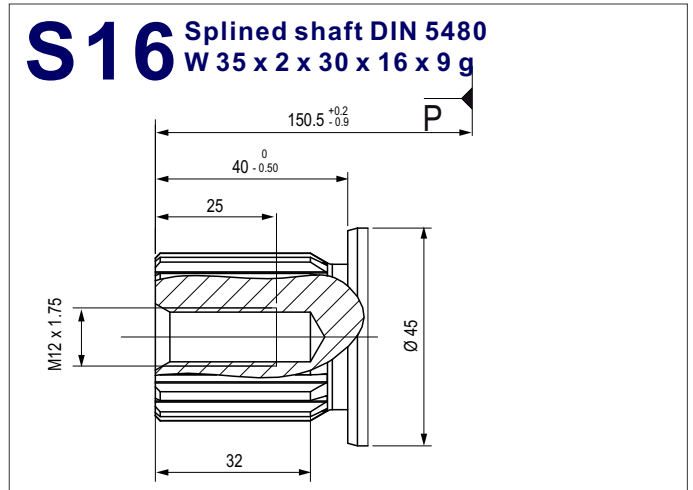
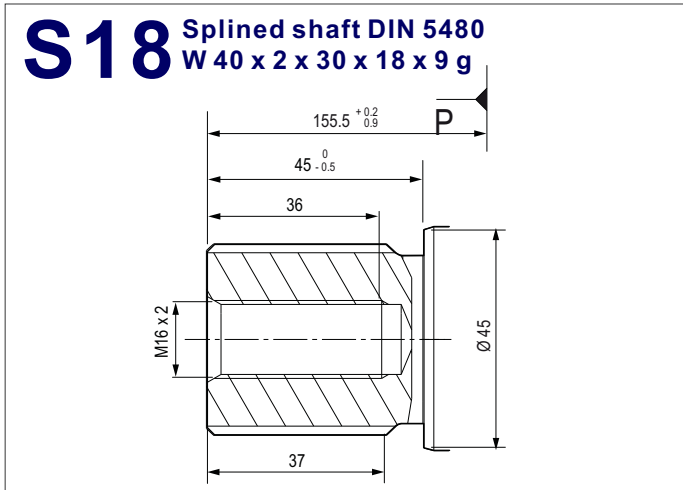
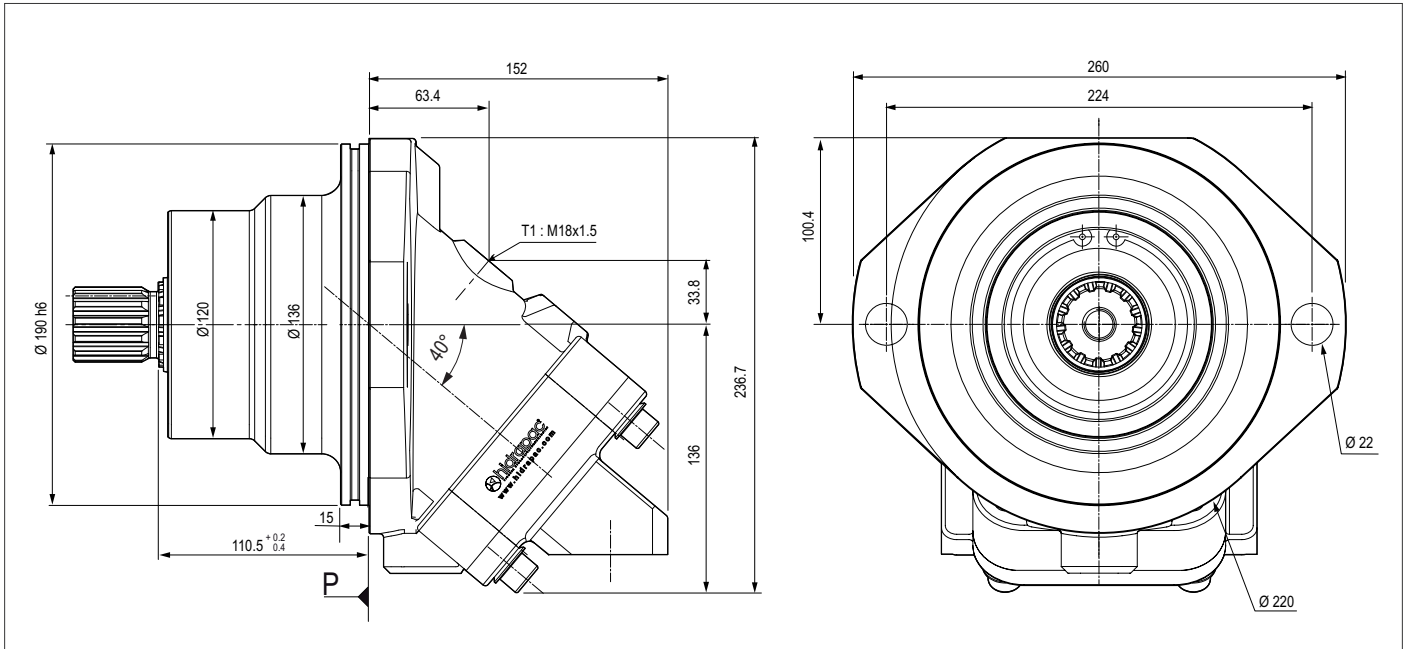

Direction of Rotation; CW/CCW

The Pumps rotate clockwise or counter-clockwise depending on the direction of hydraulic flow entering the Pump.

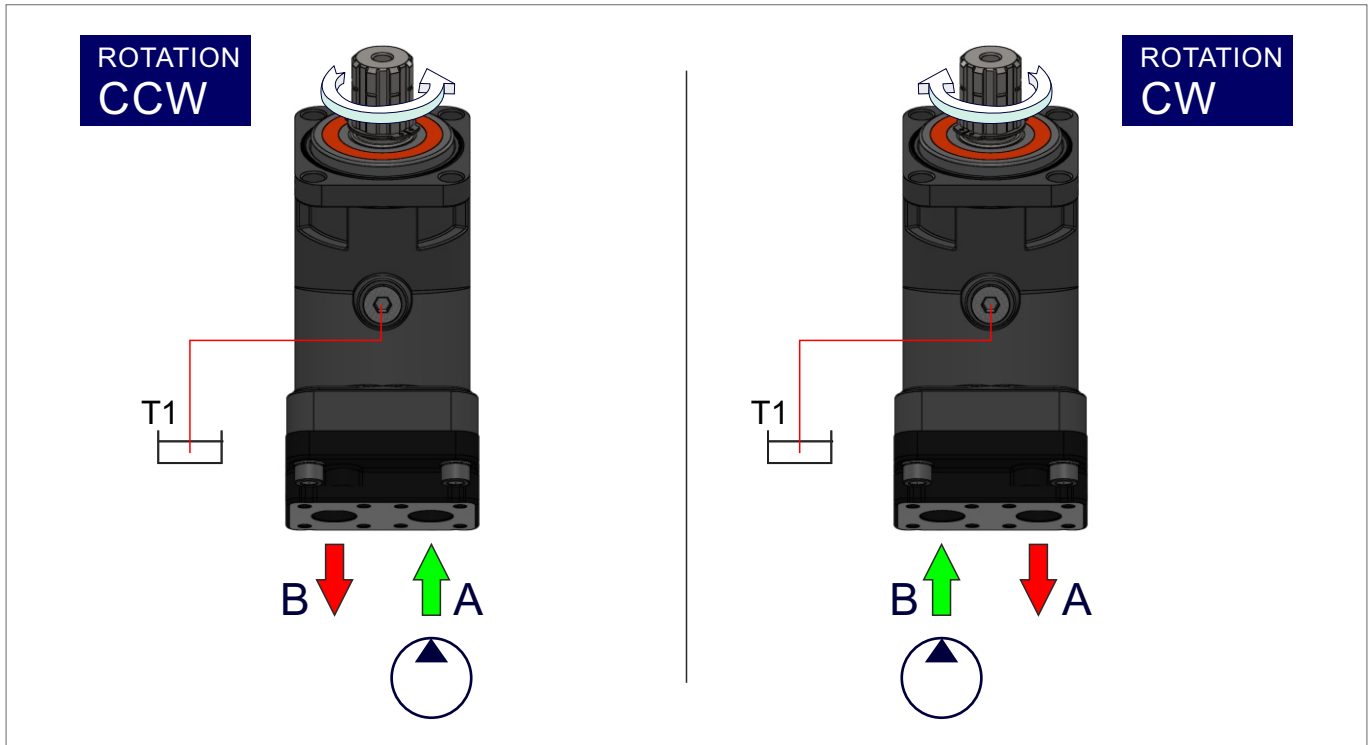

Formulas			
Pump Output Flow	GPM	$GPM = (\text{Speed (rpm)} \times \text{disp. (cu. in.)}) / 231$	$GPM = (n \times d) / 231$
Pump Input Horsepower	HP	$HP = GPM \times \text{Pressure (psi)} / 1714 \times \text{Efficiency}$	$HP = (Q \times P) / 1714 \times E$
Pump Efficiency	E	Overall Efficiency = Output HP / Input HP	$E_{\text{Overall}} = \text{HPOut} / \text{HPIn} \times 100$
		Overall Efficiency = Volumetric Eff. \times Mechanical Eff.	$E_{\text{Overall}} = \text{EffVol.} \times \text{EffMech.}$
Pump Volumetric Efficiency	E	Volumetric Efficiency = Actual Flow Rate Output (GPM) / Theoretical Flow Rate Output (GPM) \times 100	$\text{EffVol.} = \text{QAct.} / \text{QTheo.} \times 100$
Pump Mechanical Efficiency	E	Mechanical Efficiency = Theoretical Torque to Drive / Actual Torque to Drive \times 100	$\text{EffMech} = \text{TTheo.} / \text{TAct.} \times 100$
Pump Displacement	CIPR	$\text{Dsplcmnt (In.}^3 \text{ / rev.)} = \text{Flow Rate (GPM)} \times 231 / \text{Pump RPM}$	$\text{CIPR} = \text{GPM} \times 231 / \text{RPM}$
Pump Torque	T	Torque = Horsepower \times 63025 / RPM	$T = 63025 \times \text{HP} / \text{RPM}$
		Torque = Pressure (PSIG) \times Pump Displacement (CIPR) / 2π	$T = P \times \text{CIPR} / 6.28$

- Horsepower for driving a pump** : For every 1 hp of drive, the equivalent of 1 gpm @ 1500 psi can be produced.
- Horsepower for idling a pump** : To idle a pump when it is unloaded will require about 5% of it's full rated power
- Wattage for heating hydraulic oil** : Each watt will raise the temperature of 1 gallon of oil by 1° F. per hour.
- Flow velocity in hydraulic lines** : Pump suction lines 2 to 4 feet per second, pressure lines up to 500 psi - 10 to 15 ft./sec., pressure lines 500 to 3000 psi - 15 / 20 ft./sec.; all oil lines in air-over-oil systems; 4 ft./sec.

Installation & Assemble Informations for Bent Axis Pumps

POSITION

Fixed Flange Bent Axis Pumps can be operate any position.

DIRECTION OF ROTATION

Fixed Flange Bent Axis Pumps can be operate in both directions of rotation.

Before of Installation operation, the Pump must be filled with hydraulic fluid and air bled.

INSTALLATION POSITION

See following examples.

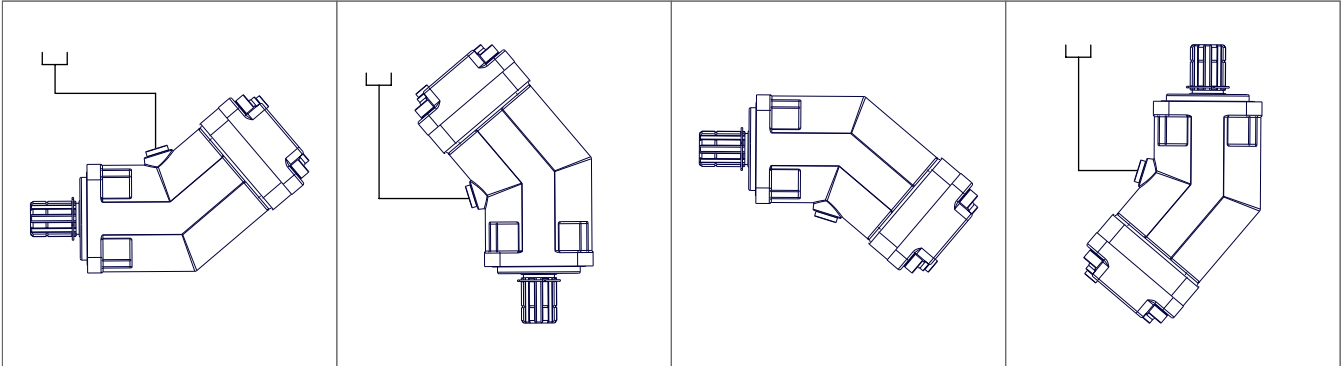

HYDRAULIC FLUID

Recommended ;

Generally : between 15 and 200 cSt.

Maximum : between 5 and 1600 cSt.

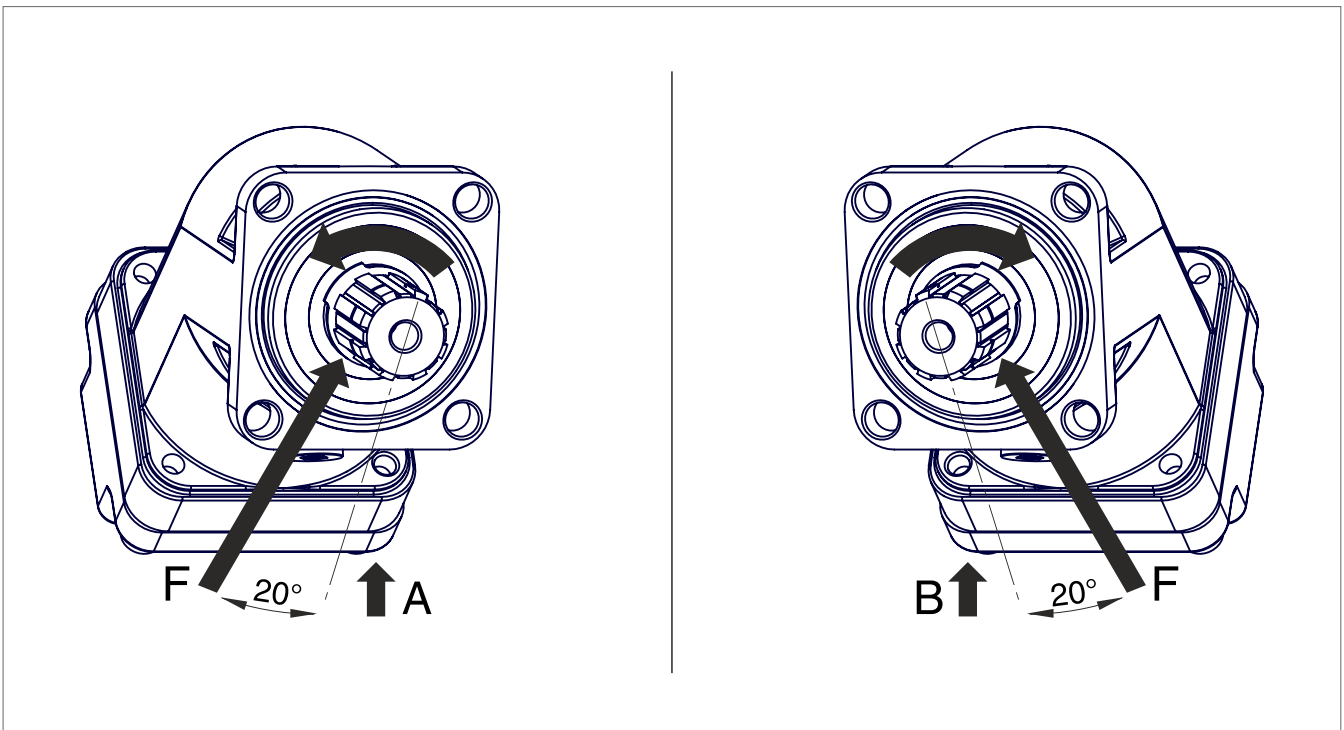

FOR USE;

Available via e-mail on request or each Pump is supplied via Starting datasheet.

Formulas, Calculations, Installation Guide

Quick Calculation

Flow rate

$$Q = \frac{V_S \cdot n}{1000 \eta_v} \text{ (lpm)}$$

Torque

$$M = \frac{V_S \cdot \Delta p \cdot \eta_{mh}}{63} \text{ (Nm)}$$

Power

$$P = \frac{2\pi \cdot M \cdot n}{60000} = \frac{M \cdot n}{9549} = \frac{Q \cdot \Delta p \cdot \eta_t}{600} \text{ (kW)}$$

Speed

$$n = \frac{1000 \cdot Q \cdot \eta_v}{V_S} \text{ (rpm)}$$

- V_S = Displacement (ccm/rev.)
 Δp = Diff. pressure (bar)
 n = Speed (rpm)
 Q = Flow (lpm)
 η_v = Volumetric efficiency
 η_{mh} = Mechanical-hydraulic efficiency
 η_t = Total efficiency ($\eta_t = \eta_v \times \eta_{mh}$)

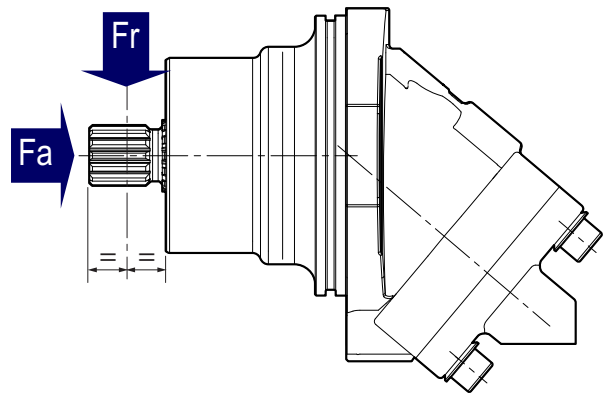

Pump model	28 cc	32 cc	41.45	50 cc	56, 63cc	80,90,108	125 cc
Fr (lbf)	1350	1462.5	1462.5	1686	2023	2812	3262
Fr (N/bar)	6000	6500	6500	7500	9000	12500	14500
Fa (lbf)	0.42	0.46	0.62	0.62	0.77	1.24	1.33
Fa (N/bar)	(27)	(30)	(40)	(40)	(50)	(80)	(86)

Other Advantages of Flange Bent Axis Pumps

Interchangeable and Compatible with other Bent Axis Pumps,
 Special Designed Pistons,
 One-Piece Piston with Piston Rings,
 For use in stationary and mobile applications,
 Compact Pump design and extra durable parts,
 High Operational Reliability and High Starting Torque
 Extra Warranty with Wide Service

Complete Product Range

Bent Axis Piston Motors

A9MD (DIN) Bent Axis Motors
A9MO (ISO) Bent Axis Motors
A9MS (SAE) Bent Axis Motors
A9ML (SAE2) Bent Axis Motors
A9MF (Fixed Plugin) Bent Axis Motors
A10M (HYBRID) Bent Axis Motors
A7GM Hydraulic Gear Motors
A7GMT Tandem Hydraulic Gear Motors

Bent Axis Piston Pumps

A8P (Aluminum) Bent Axis Pumps
A8PD (DIN) Bent Axis Pumps
A8PO (ISO) Bent Axis Pumps
A8PS (SAE) Bent Axis Pumps
A8PF (Fixed Plugin) Bent Axis Pumps
A10 (HYBRID) Bent Axis Pumps
A11 (ISO2) Bent Axis Pumps
A11 (SAE2) Bent Axis Pumps

Variable Displacement Pumps

A12V Variable Displacement Piston Pumps

Dual Flow Piston Pumps

A8PL (DIN) Dual Flow Pumps

Axial Piston & Gear Pumps

A4PP Axial Hydraulic Piston Pumps
A6HP High Pressure Piston Pumps
A7GP Hydraulic Gear Pumps
A7GPT Tandem Hydraulic Gear Pumps

Valve (ByPass) (Flushing) (Cavitation)

Circulation Valve
ByPass Valve
Anti-Cavitation Valve
Flushing Valve
LS Valve
AntiShock Valve
Speed Sensor

Hydraulic Spare Parts

Suction Fittings
Couplars
Adapters
Flanges
Power Take Off
Monoblock Valve
Section Valve

Hydraulic Pumps, Motors

Bent Axis Hydraulic Piston Motors, Bent Axis Hydraulic Piston Pumps, Piston Pumps, Variable Displacement Piston Pumps, Variable Displacement Piston Motors, Axial Piston Pumps, High Pressure Piston Pumps, Gear Pumps, Gear Motors, Hydraulic Valve.

www.hydrogold.com.tr

Address;

HYDROGOLD HİDROLİK PNM. MAK. SAN. TİC. LTD. ŞTİ.

Address; (Fabrika, İmalat)

Fevzicakmak Mah. Sıla Cad. Kobisan 3 San. Sit.

No: 73 / C Karatay – Konya, PO Code; 42050, Türkiye

Address; (Montaj, Sevkiyat)

Fevzicakmak Mah. Sıla Cad. Kobisan 3 San. Sit.

No: 71 / AD Karatay – Konya, PO Code; 42050, Türkiye

Phone; +90 332 248 92 01

info@hydrogold.com.tr