

A8PA Alüminyum Eksenel Pistonlu Pompa

New Design- Bi-Directional Rotation, Aluminum Hydraulic Bent Axis Piston Pumps, 380/420 BAR Working Pressure. High Rotational Speed, High Efficiency, Slim Design, Cast Iron Pump Body, Re-Designed in 2025.

Designation;

5cc, 10cc, 12cc, 18cc, 25cc, 32cc, 41cc, 50cc,
56cc, 63cc, 80cc, 108cc, 130cc

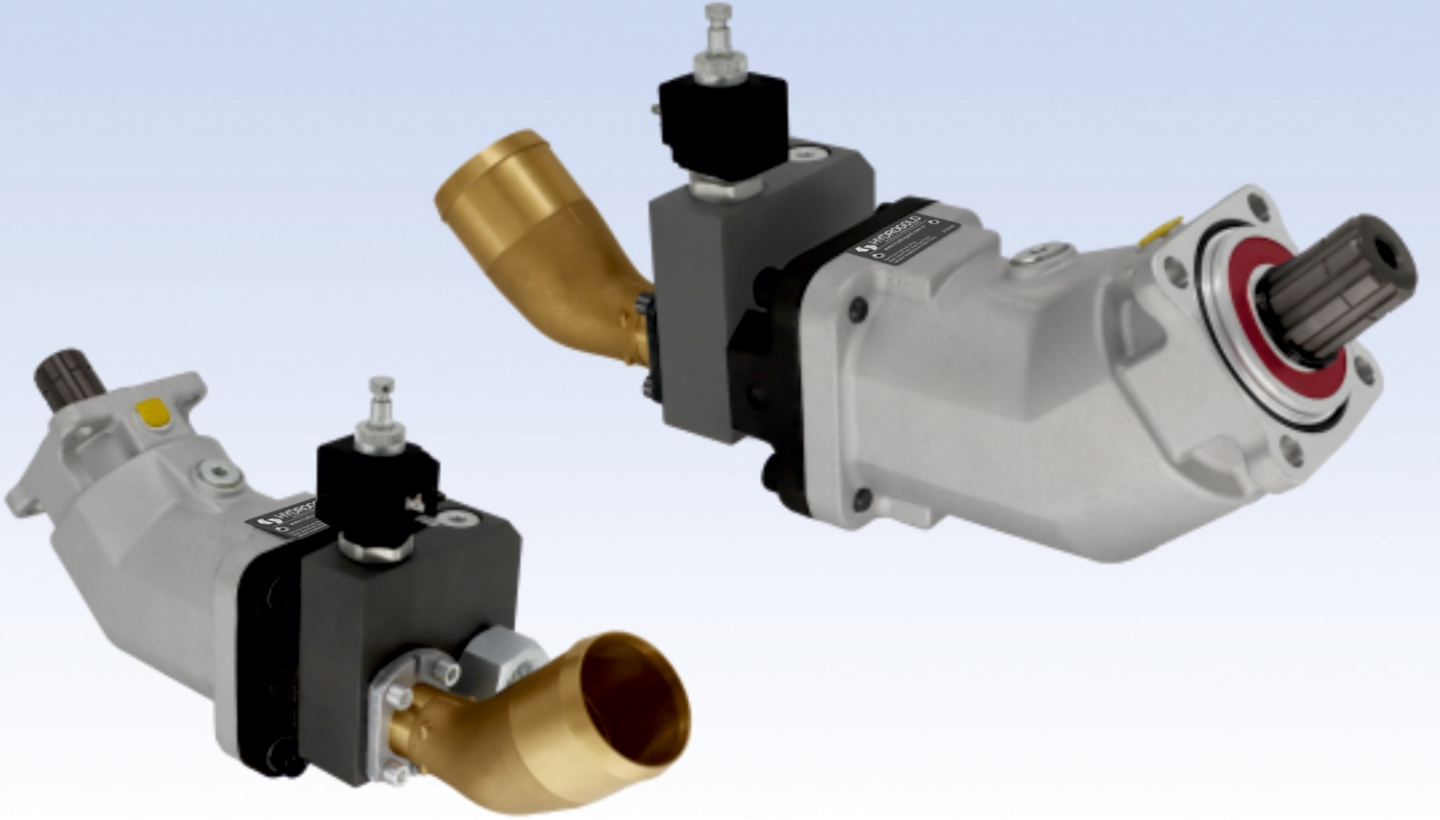

www.hydrogold.com.tr

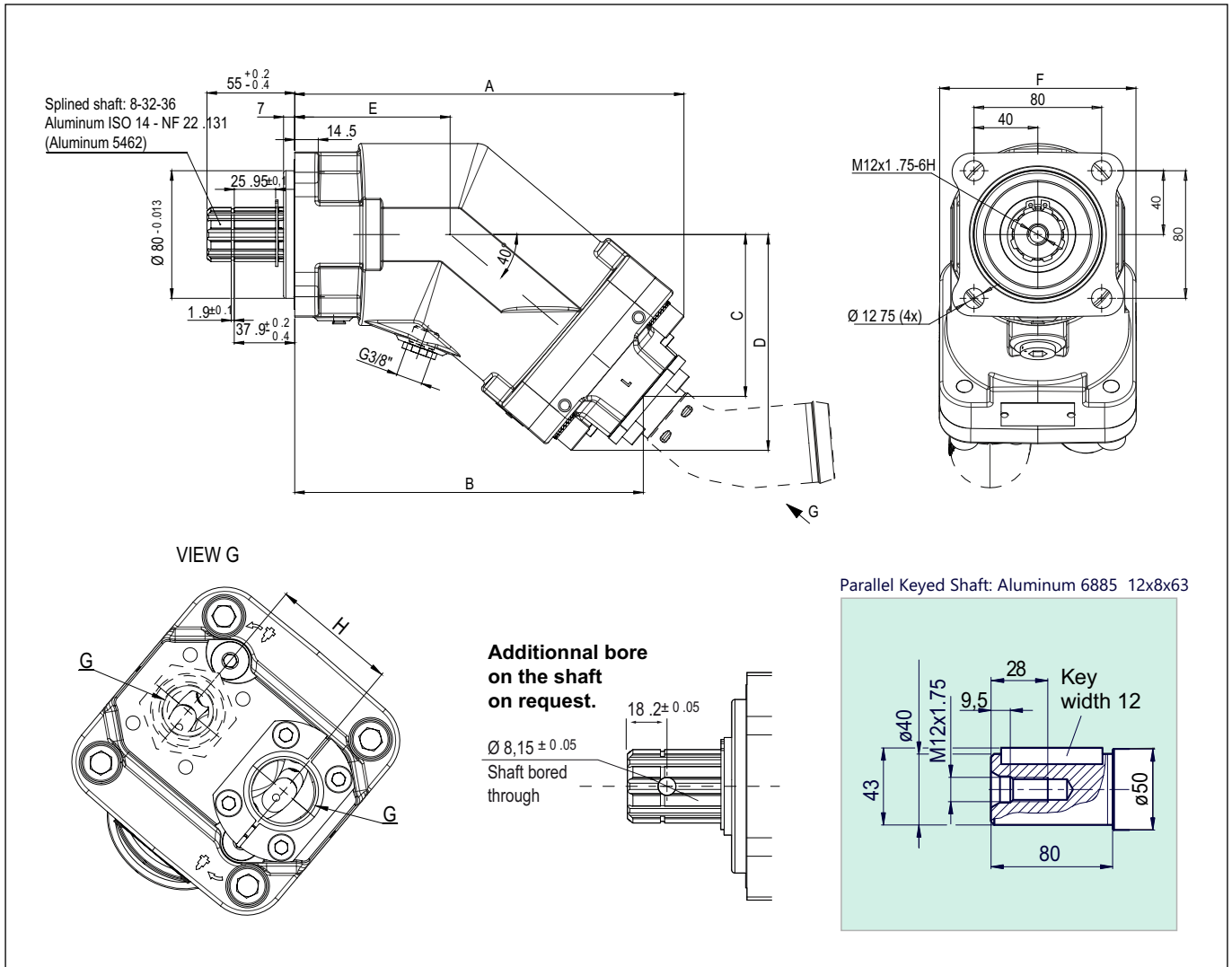

Pump MODEL	DISPL. (cc)	A	B	C	D	E	F	G	H
5 cc	5.1	196.7	177.8	77.1	103.9	85.7	108	G 3/4"	54
10 cc	10.2	196.7	177.8	77.1	103.9	85.7	108	G 3/4"	54
12 cc	12.0	196.7	177.8	77.1	103.9	85.7	108	G 3/4"	54
18 cc	18.0	196.7	177.8	77.1	103.9	85.7	108	G 3/4"	54
25 cc	25.0	196.7	177.8	77.1	103.9	85.7	108	G 3/4"	54
32 cc	32.0	202.8	184.0	82.3	109.1	85.7	108	G 3/4"	54
41 cc	41.0	202.8	184.0	82.3	109.1	85.7	108	G 3/4"	54
50 cc	50.3	214.4	195.5	92.0	118.9	85.7	108	G 3/4"	54
56 cc	56.0	214.4	195.5	92.0	118.9	85.7	108	G 3/4"	54
63 cc	63.0	214.4	195.5	92.0	118.9	85.7	108	G 3/4"	54
80 cc	80.4	241.7	220.9	103.5	133.3	97.4	123	G 1"	60
108 cc	108	241.7	222.5	104.8	133.3	97.4	123	G 1"	60
130 cc	130	244.0	224.8	106.7	135.2	97.4	123	G 1"	60

Characteristics of the A8PA - Aluminum Flange Bent Axis Pumps

Pump MODEL	DISPL. (cc)	MAX. PEAK/ CONTINUOUS PRESSURE (bar)	MAXIMUM SPEED (rpm)	MAX.TORQUE ABSORBED AT 380 BAR (N.m)	WEIGHT WITHOUT INLET FITTING (kg)	WEIGHT WITH 2" INLET FITTING (kg)	TORQUE WITHOUT FITTING (N.m)	TORQUE WITH FITTING (N.m)
5 cc	5.1	420 / 380	3300	60	9.00	9.40	8.20	8.60
10 cc	10.2	420 / 380	3200	68	9.00	9.40	8.65	9.05
12 cc	12.0	420 / 380	3150	76	9.20	9.60	8.74	9.14
18 cc	18.0	420 / 380	2900	114	9.30	9.70	8.79	9.19
25 cc	25.0	420 / 380	2750	159	11.00	11.40	8.89	9.29
32 cc	32.0	420 / 380	2700	204	11.10	11.50	11.10	11.50
41 cc	41.0	420 / 380	2550	261	11.20	11.60	11.15	11.55
50 cc	50,3	420 / 380	2450	318	11.30	11.70	11.75	12.15
56 cc	56,0	420 / 380	2400	375	11.35	11.75	11.80	12.20
63 cc	63.0	420 / 380	2300	401	11.45	11.85	11.85	12.25
80 cc	80,4	420 / 380	2150	509	14.80	15.20	17.80	18.30
108 cc	108	420 / 380	1900	687	14.90	15.30	17.92	18.42
130 cc	130	420 / 380	1750	827	15.30	15.70	18.70	19.50

Direction of Rotation; Bi-Directional

The Pumps rotate clockwise or counter-clockwise depending on the direction of hydraulic flow entering the Pump.

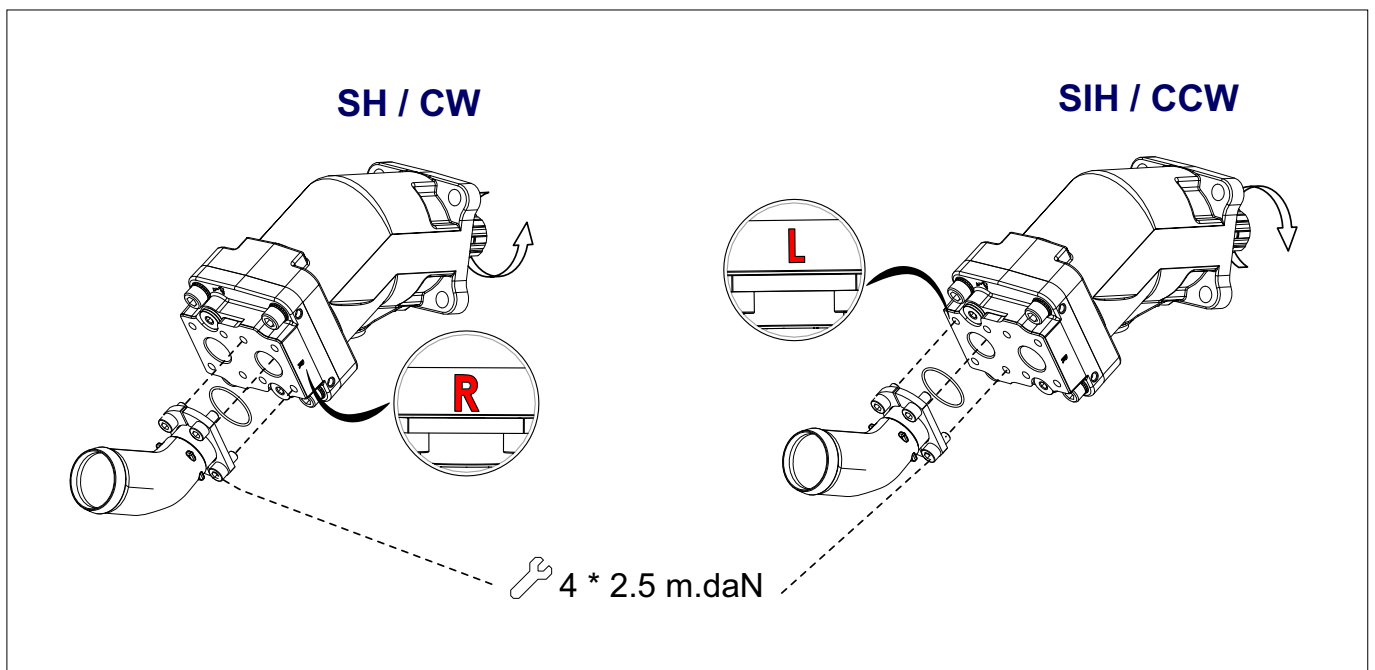

Ordering Code; A8PA - Aluminum Flange Bent Axis Pumps

Model Code	Displacement	Shaft Type	Flange Type	Rotation	Sealing
A8PA	108	S	A4	BD	V
A8PA Bent Axis Hydraulic Pump Aluminum Flange	5	S Splined Shaft (default) 8x32x36 Aluminum ISO 14NF	A4 ISO 7653 Ø80 4 Bolt Flange	BD Direction of Rotation Bi-Directional	V Viton High Pressure Seal
	10				
	12				
	18				
	25				
	32				
	41				
	50				
	56				
	63				
	80				
	108				
130	K Parallel Keyed Shaft (special) Aluminum 6885	N Nitrile Seal 5/10 Bar			

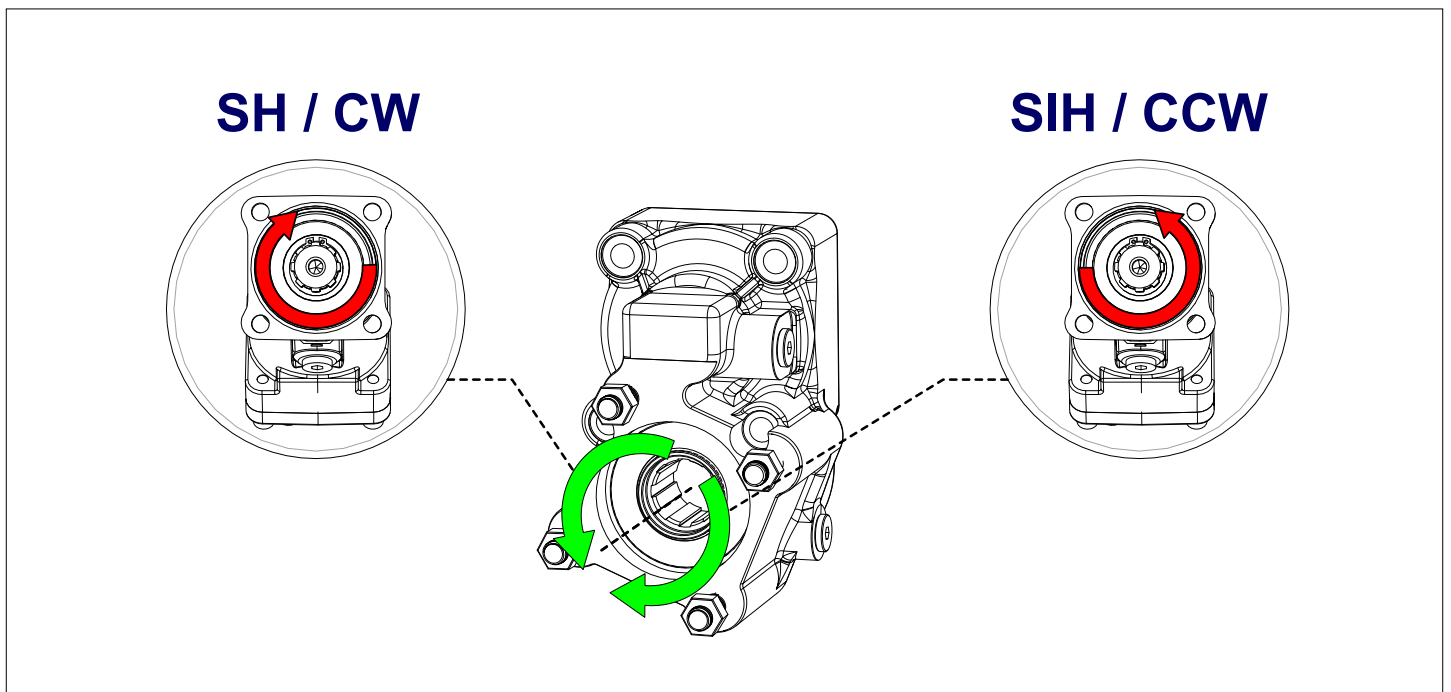

Performance, Torque, Speed and Pressure Charts

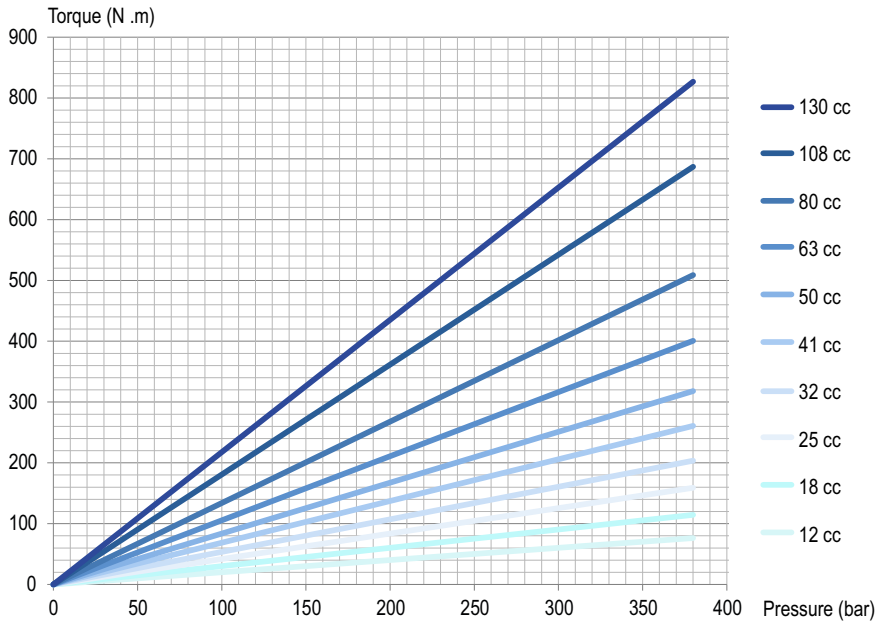

$$C = \frac{\Delta P \times Cyl \times P}{62.8 \times \eta_{meca}}$$

With:

- C = Torque in N m
- Cyl = Displacement in cc/rev
- ΔP = Differential pressure in bar
- η_{meca} = Mechanical efficiency

► Flow as a function of rotating speed

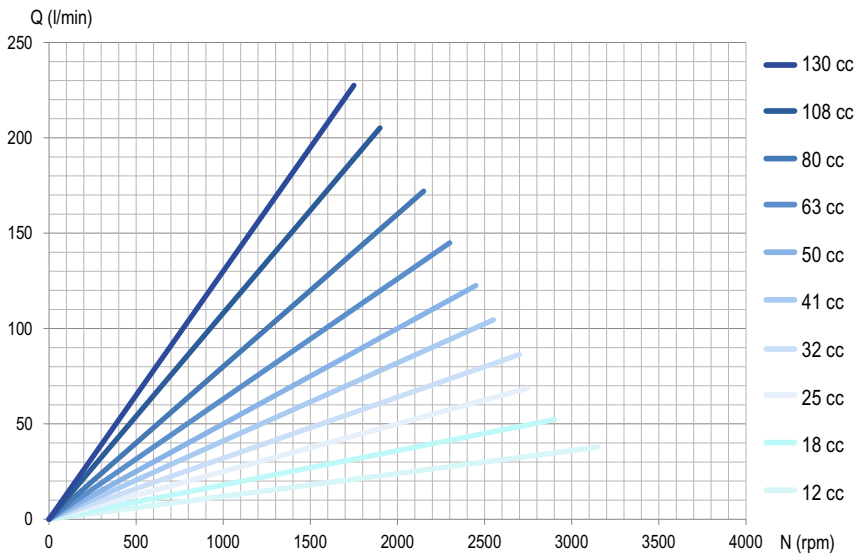

$$Q = \frac{N \times Cyl \times \eta_{vol}}{1000}$$

With:

- Q = Flow in l/min
- N = Speed in rpm
- η_{vol} = Volumetric efficiency
- Cyl = Displacement in cc/rev

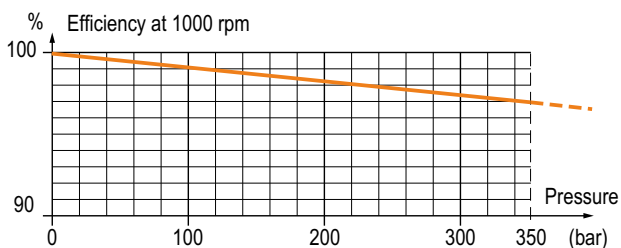

Performance, Torque, Speed and Pressure Charts

Compare Table of Torque

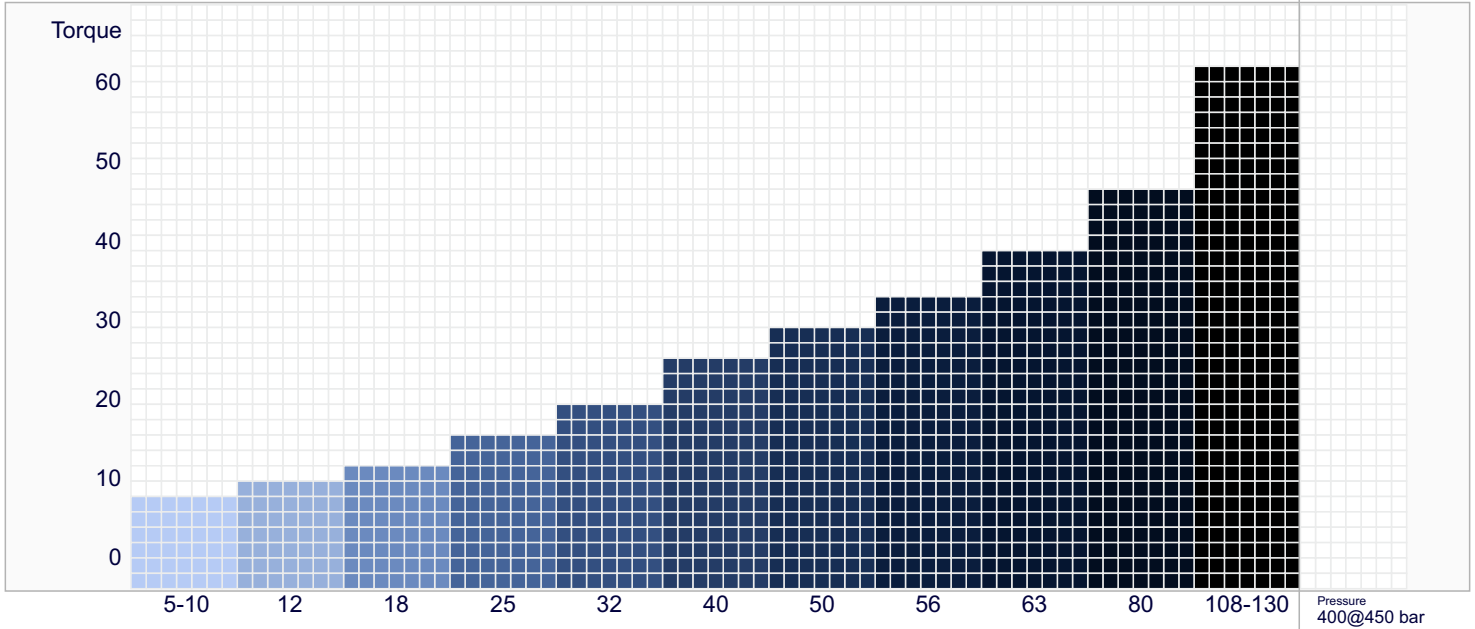

Efficiency of Bent Axis Pumps (1000 rpm)

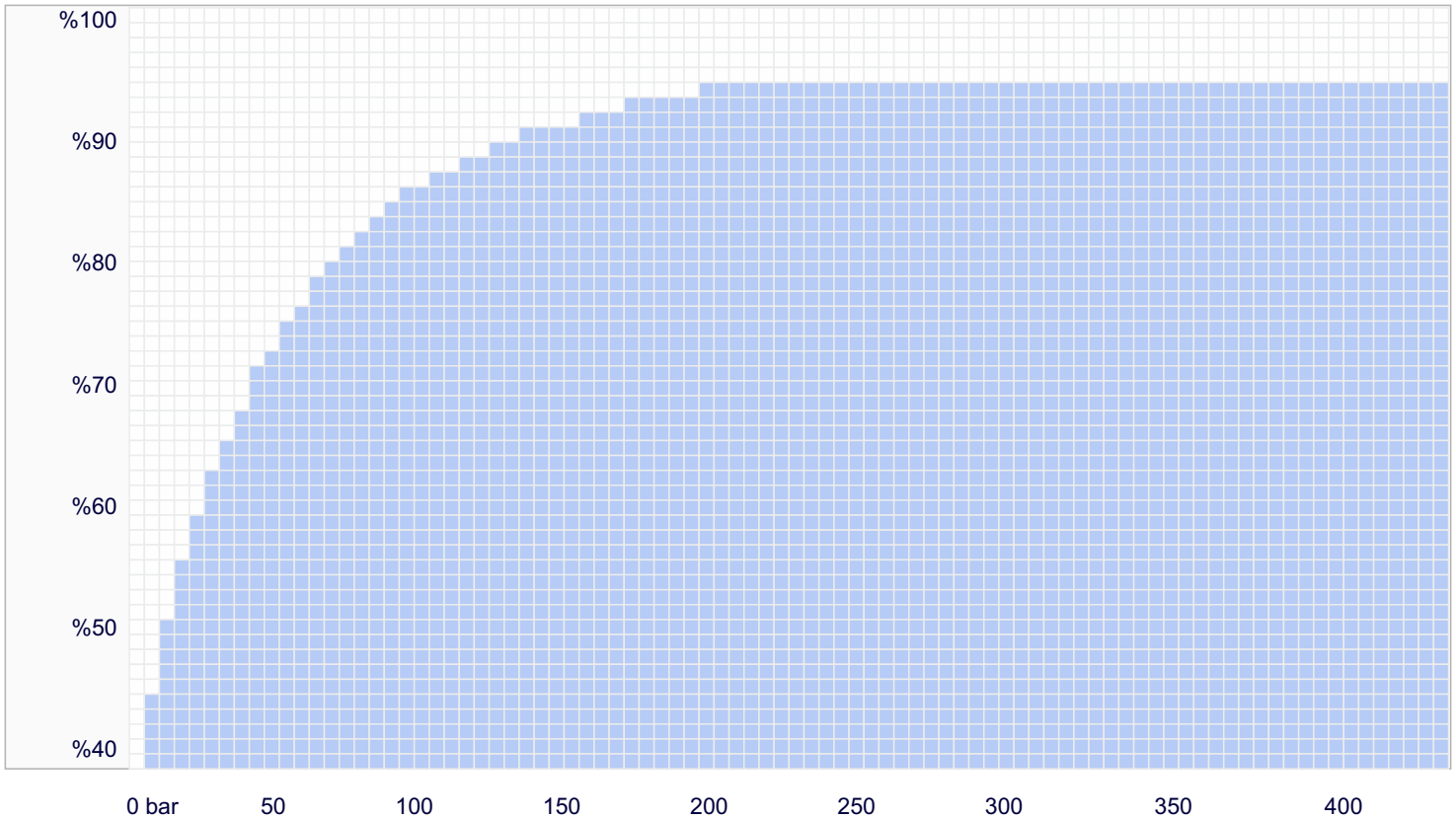

Suction Fittings for A8PA (DIN) Bent Axis Pumps

45° elbow fittings kit

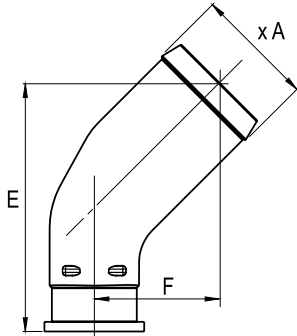

Reference	Ø hose	Ø A	E	F
450039	1 1/2"	39.1	91.7	46.7
450043	42	43	91.7	46.7
450046	1 3/4"	46	91.7	46.7
450051	2"	51.8	108.4	54.4
450064	2 1/2"	64.5	125.2	62.2

90° elbow fittings kit

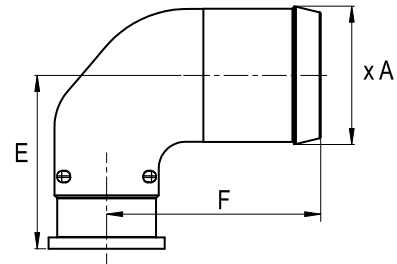

Reference	Ø hose	Ø A	E	F
900039	1 1/2"	39.1	58.6	79.5
900051	2"	51.8	64.9	80.2
900064	2 1/2"	64.5	71.3	87.5

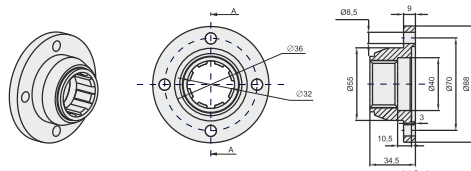
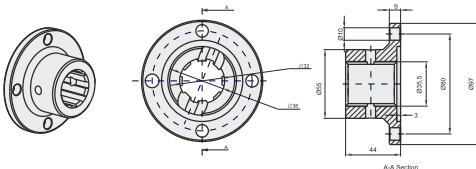
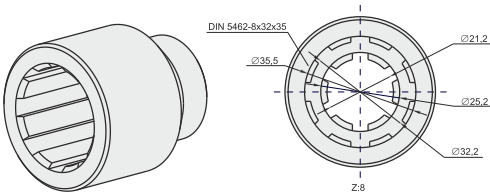
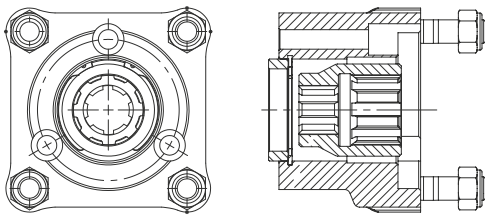

	Inlet Fittings & Installation Parts <ul style="list-style-type: none"> - Split Flange - Seal - Screw
	By-Pass Valves <ul style="list-style-type: none"> - 12 V - 24 V
	Hydraulic Adapters <ul style="list-style-type: none"> - PTO Piston Pump Adapter - PTO Gear Pump Adapter - Long / Short Adapter
	Flanges <ul style="list-style-type: none"> - 1120 (6 Spline) - 1120 (8 Spline) - 1300 (6 Spline) - 1300 (8 Spline)
	Couplars <ul style="list-style-type: none"> - 6 x 8 Couplar - 6 x 8 Couplar (Long) - 8 x 8 Couplar - 8 x 8 Couplar (Long)

ByPass Valve for A8PA (Aluminum) Bent Axis Pumps

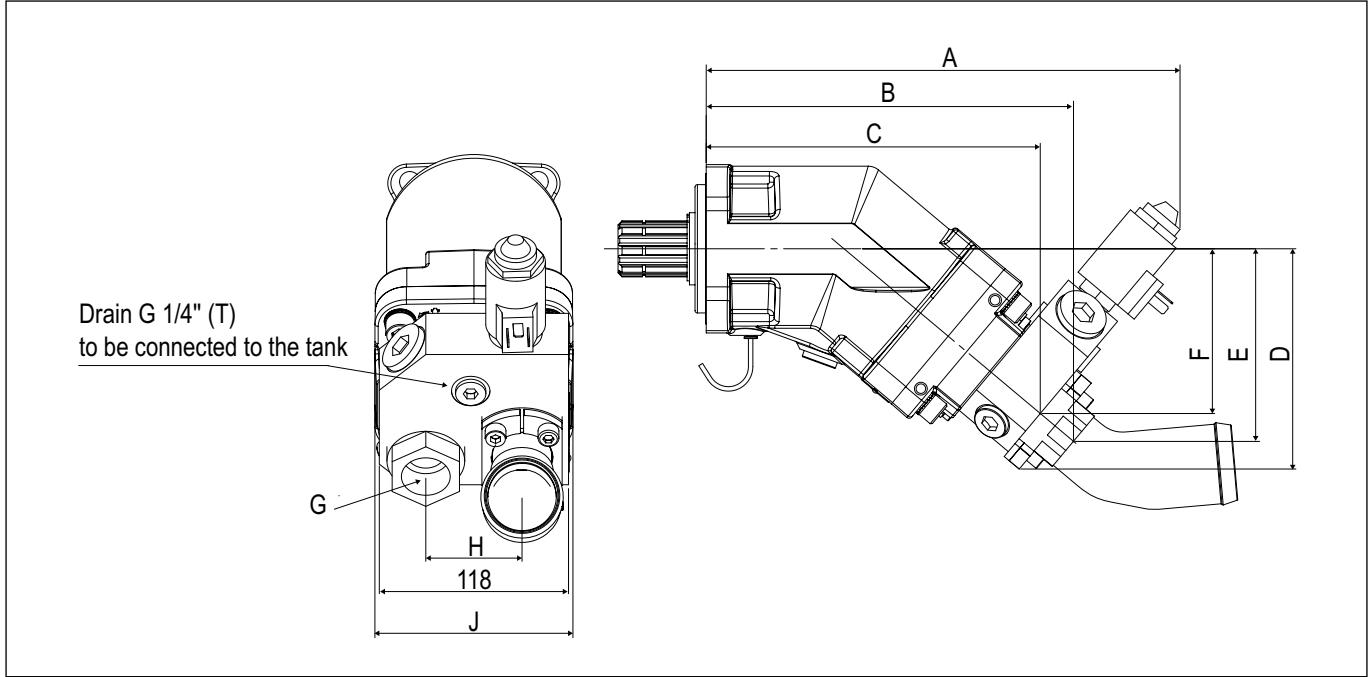

Pump MODEL	DISPL. (cc)	A	B	C	D	E	F	G	H	J
5 cc	5.1	289.35	223.04	202.19	132.20	114.72	97.58	G 3/4"	54	108
10 cc	10.2	289.35	223.04	202.19	132.20	114.72	97.58	G 3/4"	54	108
12 cc	12.0	289.35	223.04	202.19	132.20	114.72	97.58	G 3/4"	54	108
18 cc	18.0	289.35	223.04	202.19	132.20	114.72	97.58	G 3/4"	54	108
25 cc	25.0	289.35	223.04	202.19	132.20	114.72	97.58	G 3/4"	54	108
32 cc	32.0	295.50	229.00	208.30	137.30	120.10	102.70	G 3/4"	54	108
41 cc	41.0	295.50	229.00	208.30	137.30	120.10	102.70	G 3/4"	54	108
50 cc	50,3	307.10	240.40	220.00	147.10	129.70	112.50	G 3/4"	54	108
56 cc	56,0	307.10	240.40	220.00	147.10	129.70	112.50	G 3/4"	54	108
63 cc	63.0	307.10	240.40	220.00	147.10	129.70	112.50	G 3/4"	54	108
80 cc	80,4	334.00	269.00	246.70	157.80	143.90	124.80	G 1"	60	123
108 cc	108	334.00	269.00	246.70	157.80	143.90	124.80	G 1"	60	123
130 cc	130	336.30	271.3	249.00	159.70	145.80	126.70	G 1"	60	123

ByPass Valve for A8PA (Aluminum) Bent Axis Pumps

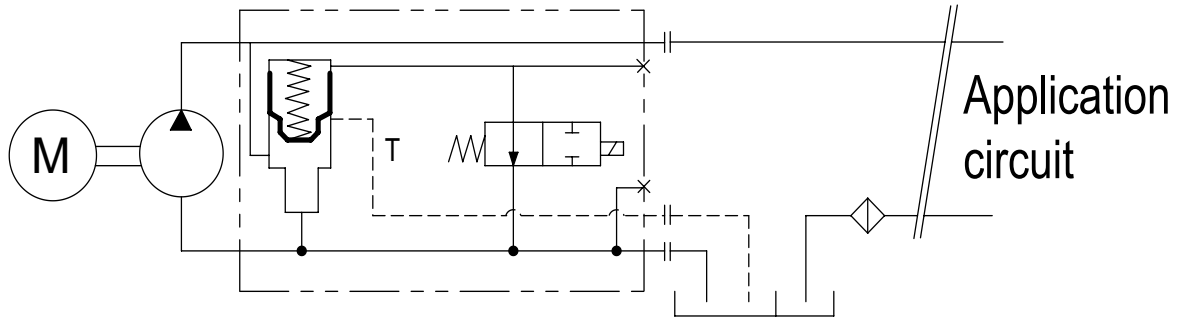

Pump MODEL	DISPL. (cc)	WEIGHT WITHOUT INLET FITTING (kg)	WEIGHT WITH 2" INLET FITTING (kg)	TORQUE WITHOUT FITTING (N.m)	TORQUE WITH FITTING (N.m)
5 cc	5.1	9.00	9.40	8.20	8.60
10 cc	10.2	9.00	9.40	8.65	9.05
12 cc	12.0	9.20	9.60	8.74	9.14
18 cc	18.0	9.30	9.70	8.79	9.19
25 cc	25.0	11.00	11.40	8.89	9.29
32 cc	32.0	11.10	11.50	11.10	11.50
41 cc	41.0	11.20	11.60	11.15	11.55
50 cc	50,3	11.30	11.70	11.75	12.15
56 cc	56,0	11.35	11.75	11.80	12.20
63 cc	63.0	11.45	11.85	11.85	12.25
80 cc	80,4	14.80	15.20	17.80	18.30
108 cc	108	14.90	15.30	17.92	18.42
130 cc	130	15.30	15.70	18.70	19.50

40° bent axis design giving high power, small overall dimensions, optimum efficiency and economic design. Flange and shaft designed for direct mounting on truck gearbox PTO's. The fixed displacement bent axis pumps generates a hydraulic fluid flow. It is designed for use in trucks, commercial vehicles and all stationary hydraulic applications. The Pump a fixed pump with rotary group in bent-axis design open circuits. Flow is proportional to drive speed and displacement.

For axial piston units with bent-axis design, the Pistons are arranged diagonally with respect to the drive shaft. The pump covers the whole displacement range 5 to 130 cm³/rev. The pump has been developed with modern styling and design to satisfy market demand as to designed new generation plate and pistons with give high flow performance, high pressures with high efficiency and very small dimensions.

The pump is available both to Aluminum and world standards and can be mounted either directly at the gear box or via a drive shaft. If necessary it can also be augmented with a by-pass valve. Other brand bent axis pumps compatible and interchangeable with Aluminum bent axis pumps. Refer to the data sheet order confirmation for the technical data, operating conditions and operating limits of the bent axis piston pumps.

Formulas			
Pump Output Flow	GPM	$GPM = (\text{Speed (rpm)} \times \text{disp. (cu. in.)}) / 231$	$GPM = (n \times d) / 231$
Pump Input Horsepower	HP	$HP = GPM \times \text{Pressure (psi)} / 1714 \times \text{Efficiency}$	$HP = (Q \times P) / 1714 \times E$
Pump Efficiency	E	Overall Efficiency = Output HP / Input HP	$E_{\text{Overall}} = \text{HPOut} / \text{HPIn} \times 100$
		Overall Efficiency = Volumetric Eff. × Mechanical Eff.	$E_{\text{Overall}} = \text{EffVol.} \times \text{EffMech.}$
Pump Volumetric Efficiency	E	Volumetric Efficiency = Actual Flow Rate Output (GPM) / Theoretical Flow Rate Output (GPM) × 100	$\text{EffVol.} = \text{QAct.} / \text{QTheo.} \times 100$
Pump Mechanical Efficiency	E	Mechanical Efficiency = Theoretical Torque to Drive / Actual Torque to Drive × 100	$\text{EffMech} = \text{TTheo.} / \text{TAct.} \times 100$
Pump Displacement	CIPR	$\text{Dsplcmnt (In.}^3 \text{ / rev.)} = \text{Flow Rate (GPM)} \times 231 / \text{Pump RPM}$	$\text{CIPR} = \text{GPM} \times 231 / \text{RPM}$
Pump Torque	T	Torque = Horsepower × 63025 / RPM	$T = 63025 \times \text{HP} / \text{RPM}$
		Torque = Pressure (PSIG) × Pump Displacement (CIPR) / 2π	$T = P \times \text{CIPR} / 6.28$

- Horsepower for driving a pump** : For every 1 hp of drive, the equivalent of 1 gpm @ 1500 psi can be produced.
- Horsepower for idling a pump** : To idle a pump when it is unloaded will require about 5% of it's full rated power
- Wattage for heating hydraulic oil** : Each watt will raise the temperature of 1 gallon of oil by 1° F. per hour.
- Flow velocity in hydraulic lines** : Pump suction lines 2 to 4 feet per second, pressure lines up to 500 psi - 10 to 15 ft./sec., pressure lines 500 to 3000 psi - 15 to 20 ft./sec.; all oil lines in air-over-oil systems; 4 ft./sec.

Complete Product Range

Bent Axis Piston Motors

A9MD (DIN) Bent Axis Motors
A9MO (ISO) Bent Axis Motors
A9MS (SAE) Bent Axis Motors
A9ML (SAE2) Bent Axis Motors
A9MF (Fixed Plugin) Bent Axis Motors
A10M (HYBRID) Bent Axis Motors
A7GM Hydraulic Gear Motors
A7GMT Tandem Hydraulic Gear Motors

Bent Axis Piston Pumps

A8PA (Aluminum) Bent Axis Pumps
A8PAD (DIN) Bent Axis Pumps
A8PAO (ISO) Bent Axis Pumps
A8PAS (SAE) Bent Axis Pumps
A8PAF (Fixed Plugin) Bent Axis Pumps
A10 (HYBRID) Bent Axis Pumps
A11 (ISO2) Bent Axis Pumps
A11 (SAE2) Bent Axis Pumps

Variable Displacement Pumps

A12V Variable Displacement Piston Pumps

Dual Flow Piston Pumps

A8PAL (DIN) Dual Flow Pumps

Axial Piston & Gear Pumps

A4PP Axial Hydraulic Piston Pumps
A6HP High Pressure Piston Pumps
A7GP Hydraulic Gear Pumps
A7GPT Tandem Hydraulic Gear Pumps

Valve (ByPass) (Flushing) (Cavitation)

Circulation Valve
ByPass Valve
Anti-Cavitation Valve
Flushing Valve
LS Valve
AntiShock Valve
Speed Sensor

Hydraulic Spare Parts

Suction Fittings
Couplars
Adapters
Flanges
Power Take Off
Monoblock Valve
Section Valve

Hydraulic Pumps, Motors

Bent Axis Hydraulic Piston Motors, Bent Axis Hydraulic Piston Pumps, Piston Pumps, Variable Displacement Piston Pumps, Variable Displacement Piston Motors, Axial Piston Pumps, High Pressure Piston Pumps, Gear Pumps, Gear Motors, Hydraulic Valve.

www.hydrogold.com.tr

Address;

HYDROGOLD HİDROLİK PNM. MAK. SAN. TİC. LTD. ŞTİ.

Address; (Fabrika, İmalat)

Fevzicakmak Mah. Sıla Cad. Kobisan 3 San. Sit.

No: 73 / C Karatay – Konya, PO Code; 42050, Türkiye

Address; (Montaj, Sevkiyat)

Fevzicakmak Mah. Sıla Cad. Kobisan 3 San. Sit.

No: 71 / AD Karatay – Konya, PO Code; 42050, Türkiye

Phone; +90 332 248 92 01

info@hydrogold.com.tr